

BillyOh Keeper Overlap
Apex Range[®]
Windowless
Technical Details



For Queries and Help
please call Product
Support:
01636 858377

6ft Gable Windowless Overlap Shed

Double Door Range

Front elevation: width 2.009m/6' 7"

Sizes available

available in standard 7mm cladding types

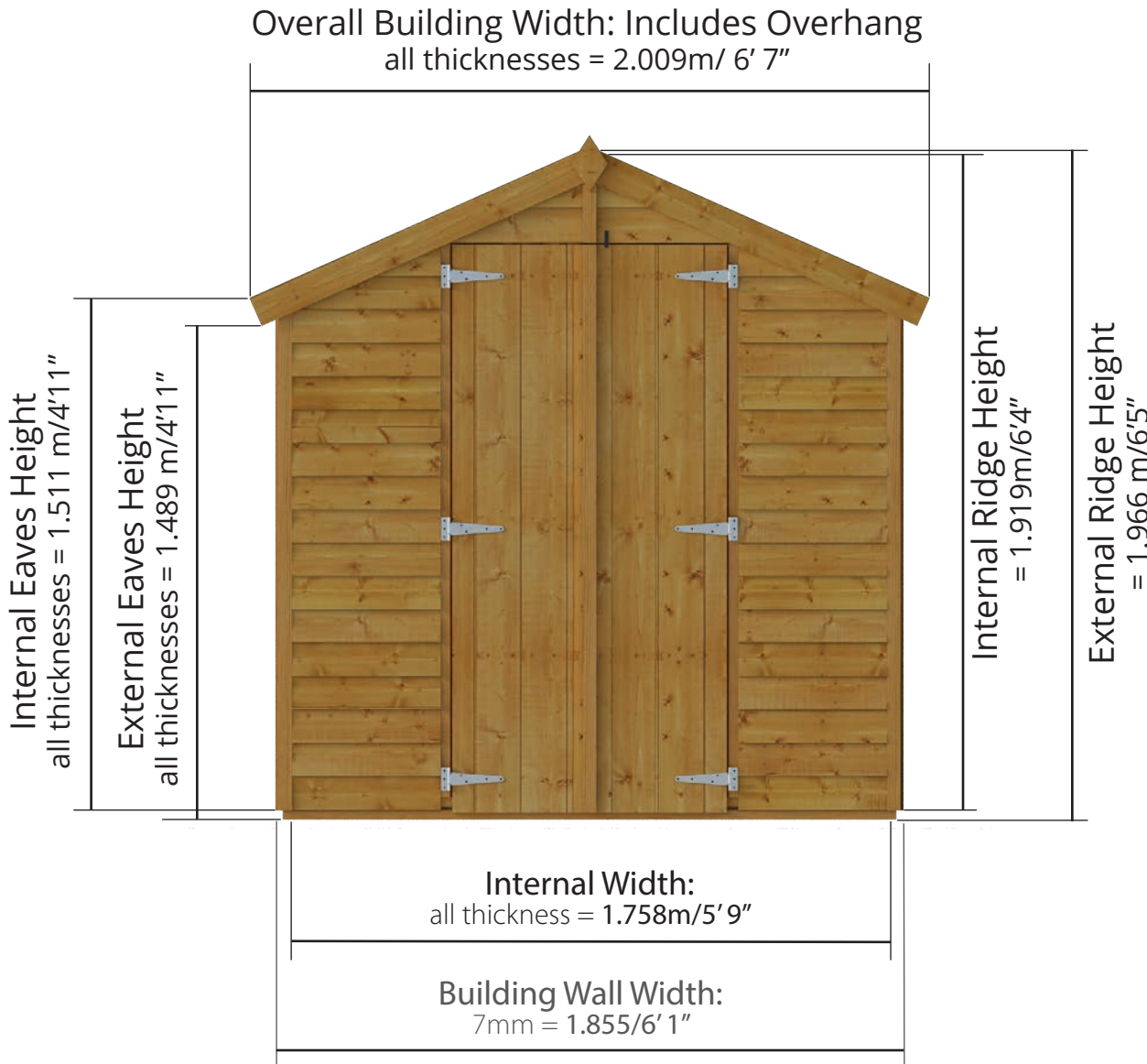

Windowless OL Shed
D12ft x W6ft
(Including Overhang)



Windowless OL Shed
D16ft x W6ft
(Including Overhang)



Windowless OL Shed
D8ft x W6ft
(Including Overhang)



Windowless OL Shed
D10ft x W6ft
(Including Overhang)



Windowless OL Shed
D4ft x W6ft
(Including Overhang)



D4.754m x W2.009m / D6' 7" x W16' 7"

Windowless Overlap Apex Shed:

Side elevation

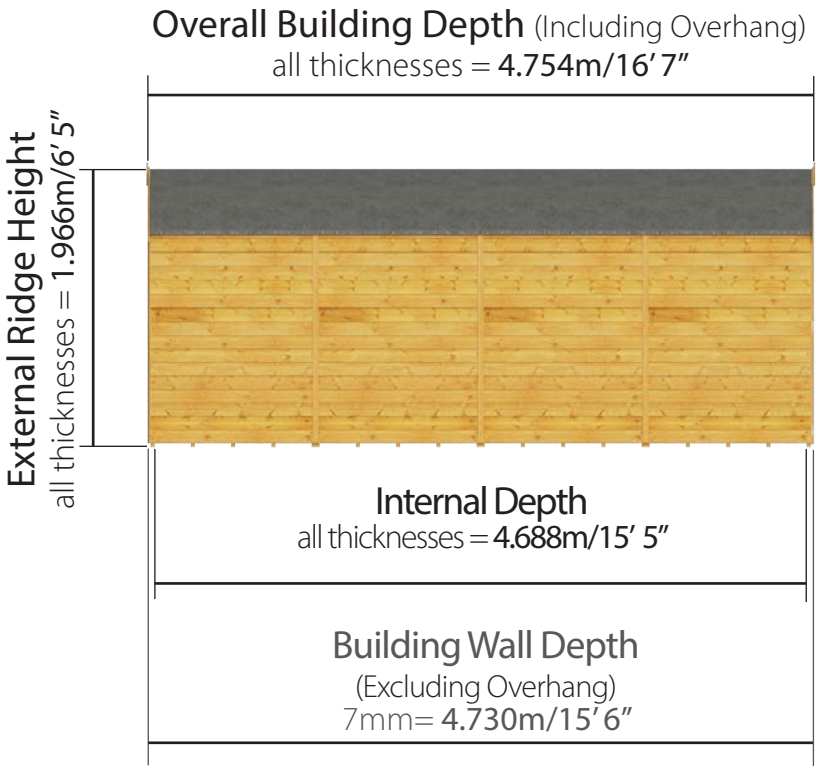

Side of Building

Floor Plan

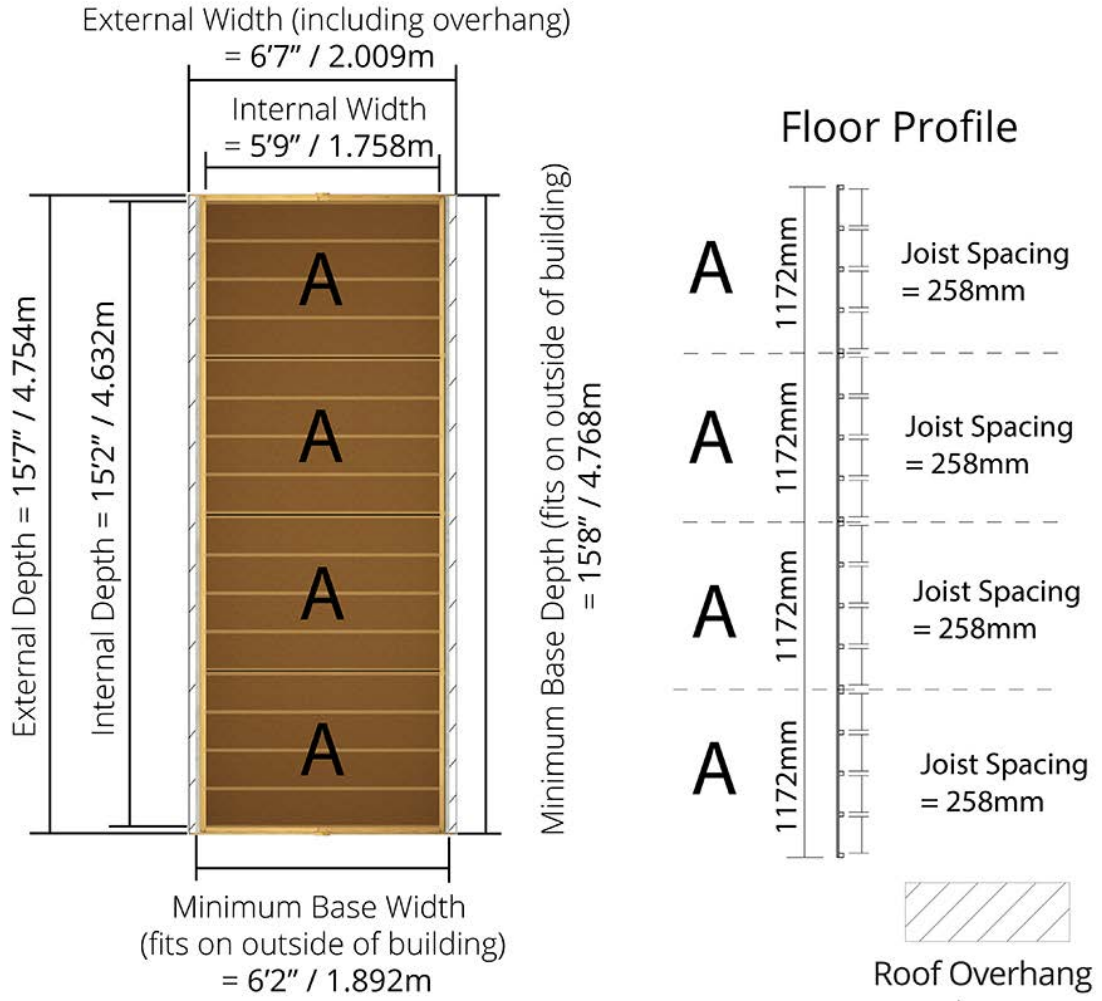

Front of Building

Please note: your base must be perfectly level and drainage is required to allow water to run off the surface. There must also be at least 2m clearance on each side to allow annual treatment to be applied.

D4.754m x W2.009m / D6' 7" x W11' 9"

Windowless Overlap Apex Shed:

Side elevation

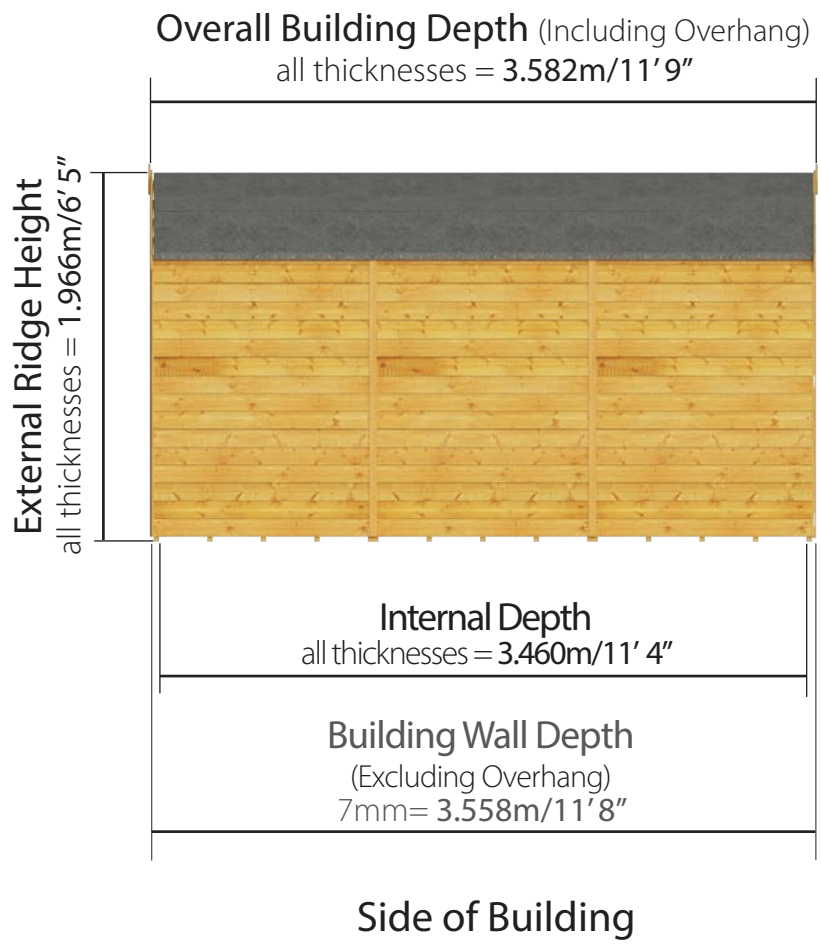

Floor Plan

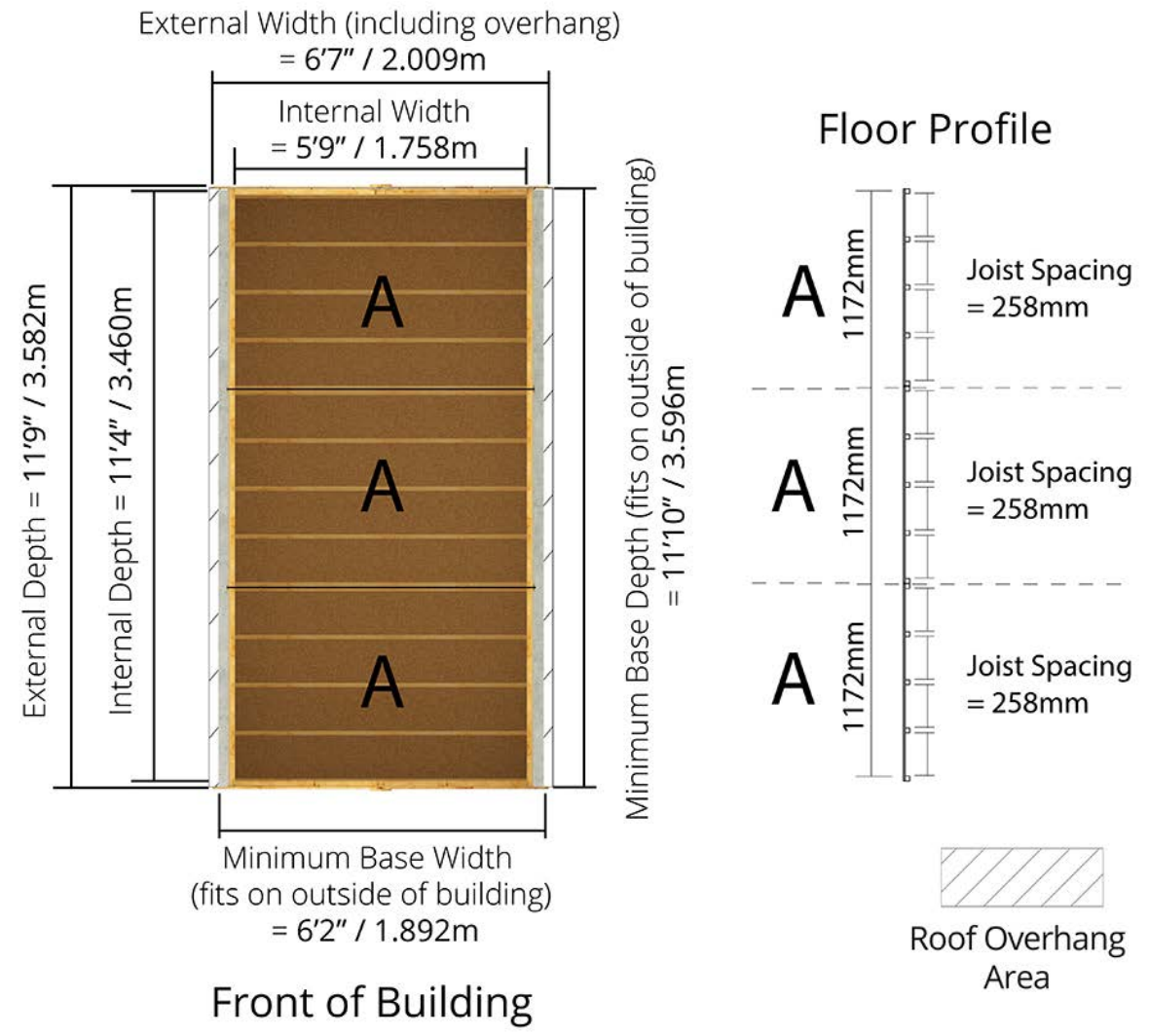

Please note: your base must be perfectly level and drainage is required to allow water to run off the surface. There must also be at least 2m clearance on each side to allow annual treatment to be applied.

D2.996m x W2.009m / D6' 7" x W9' 10"

Windowless Overlap Apex Shed:

Side elevation

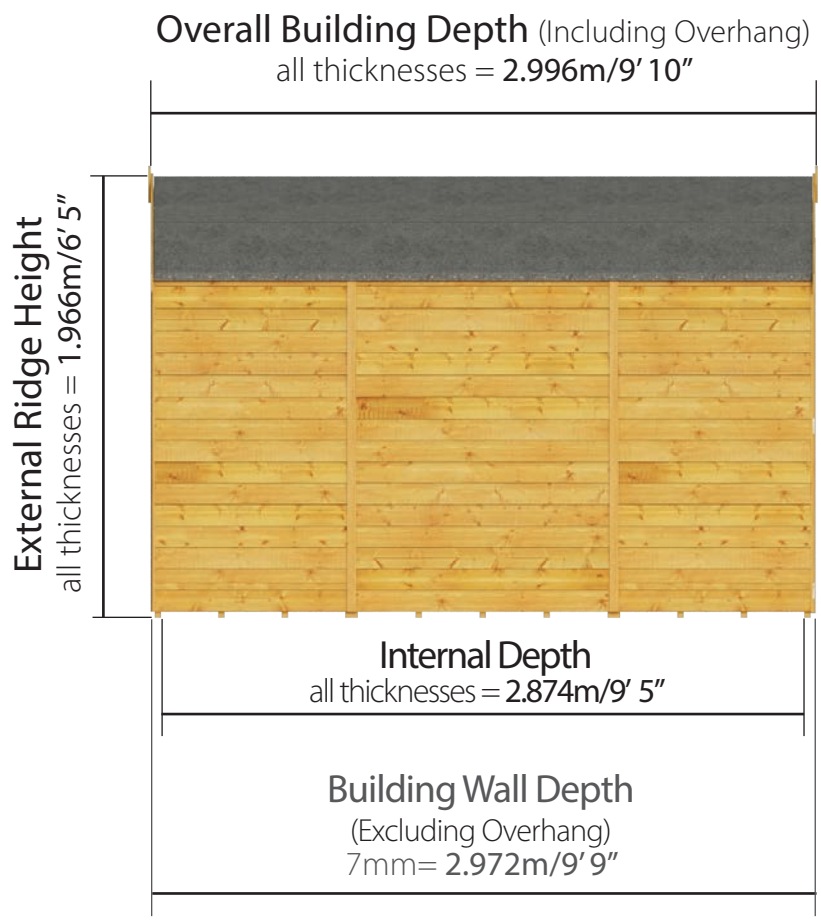

Side of Building

Floor Plan

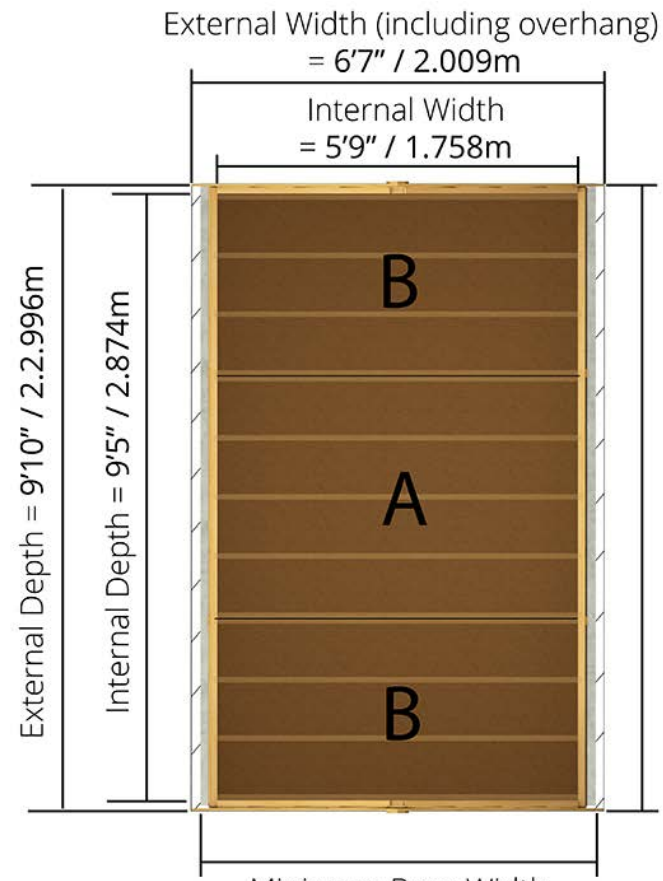

Front of Building

Floor Profile

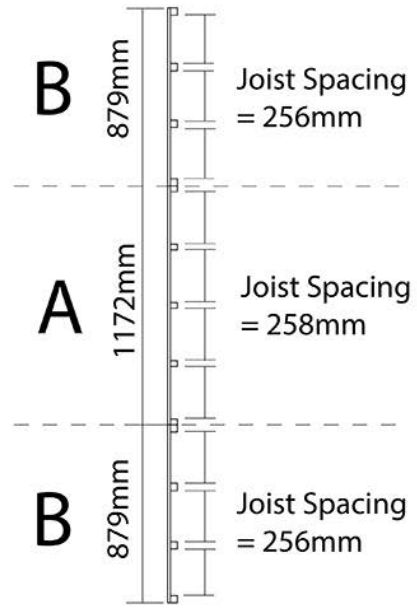

Minimum Base Depth (fits on outside of building)
= 9'11" / 3.010m



Roof Overhang Area

Please note: your base must be perfectly level and drainage is required to allow water to run off the surface. There must also be at least 2m clearance on each side to allow annual treatment to be applied.

D2.410m x W2.009m / D6' 7" x W7' 11"

Windowless Overlap Apex Shed:

Side elevation

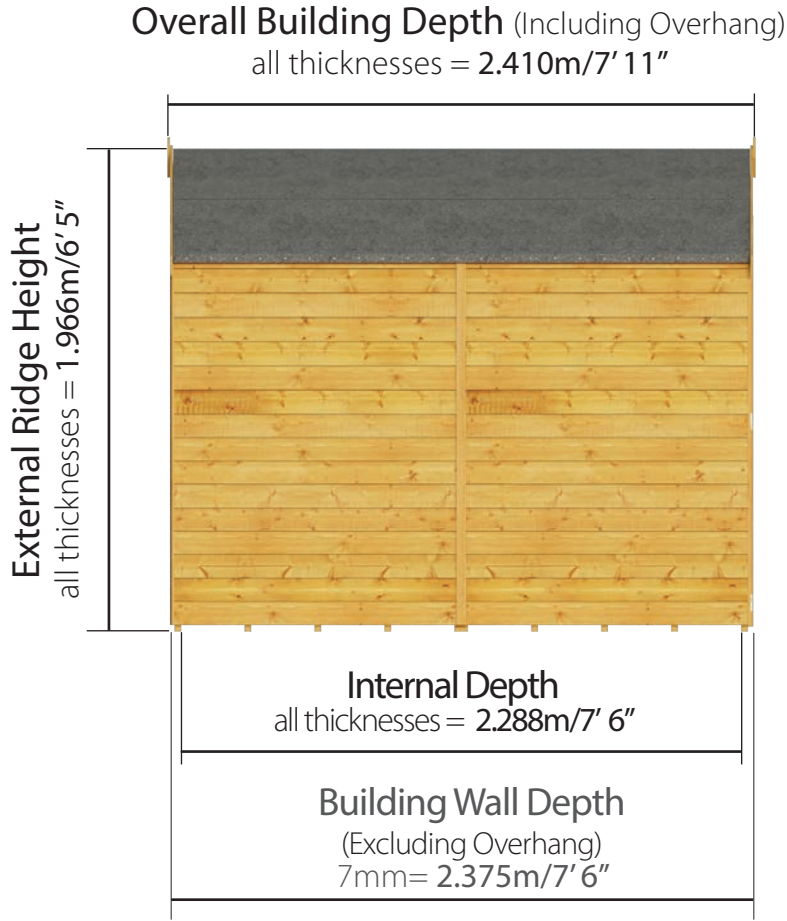

Side of Building

Floor Plan

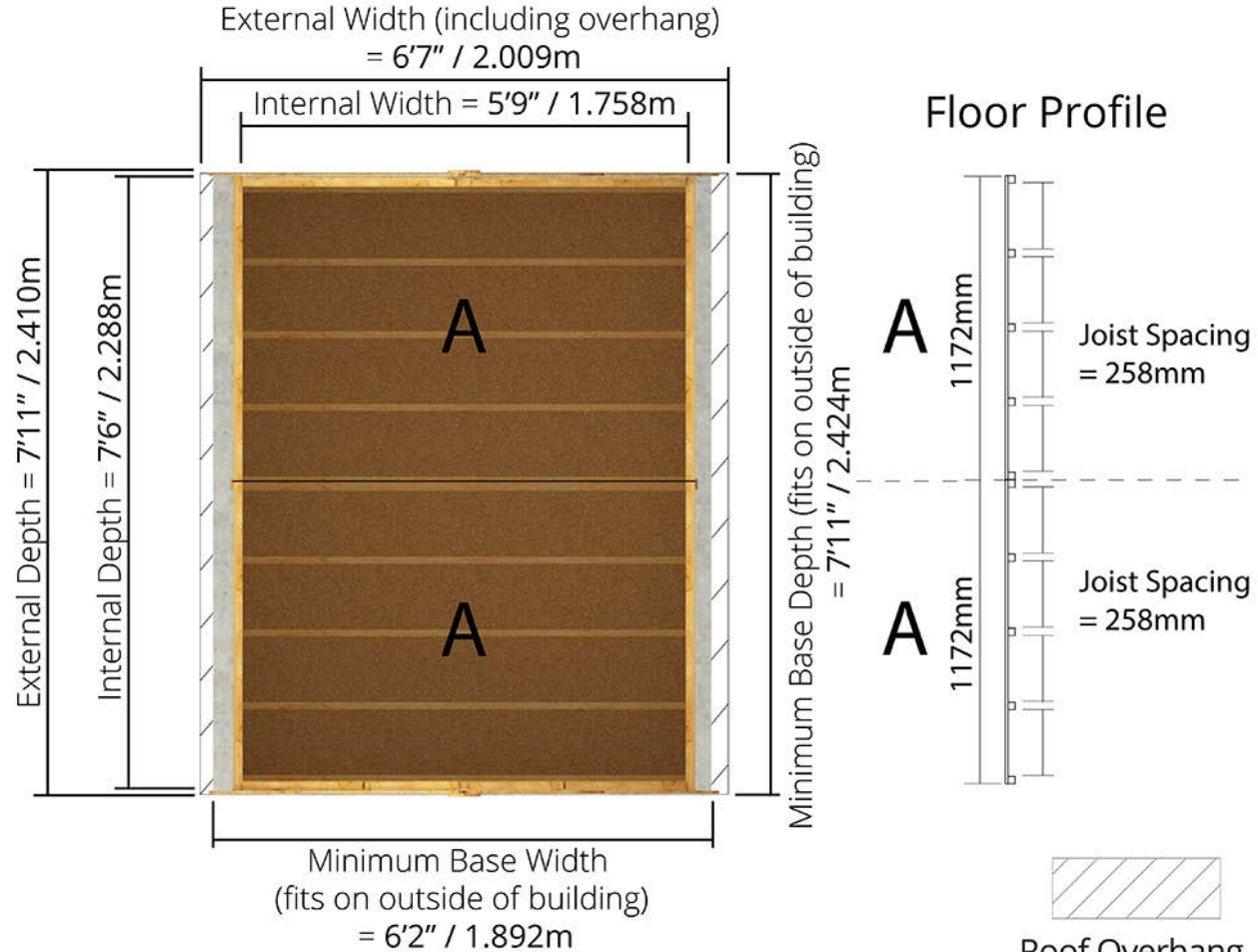

Front of Building

Please note: your base must be perfectly level and drainage is required to allow water to run off the surface. There must also be at least 2m clearance on each side to allow annual treatment to be applied.

D1.238m x W2.009m / D6' 7" x W4'1"

Windowless Overlap Apex Shed:

Side elevation

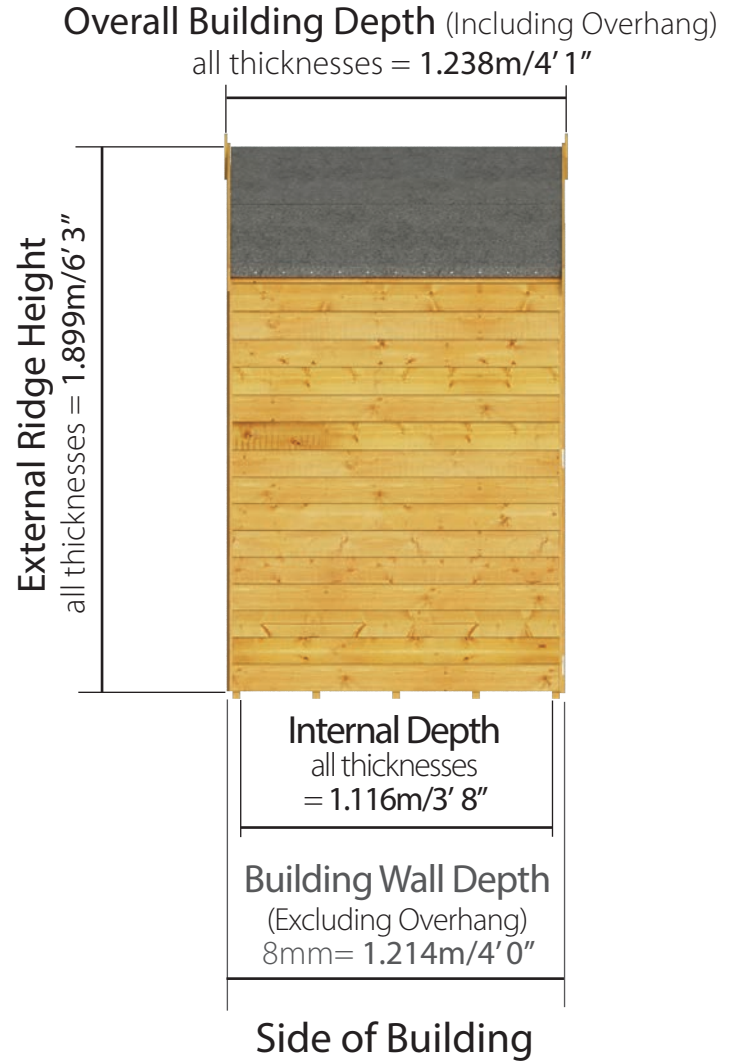

Floor Plan

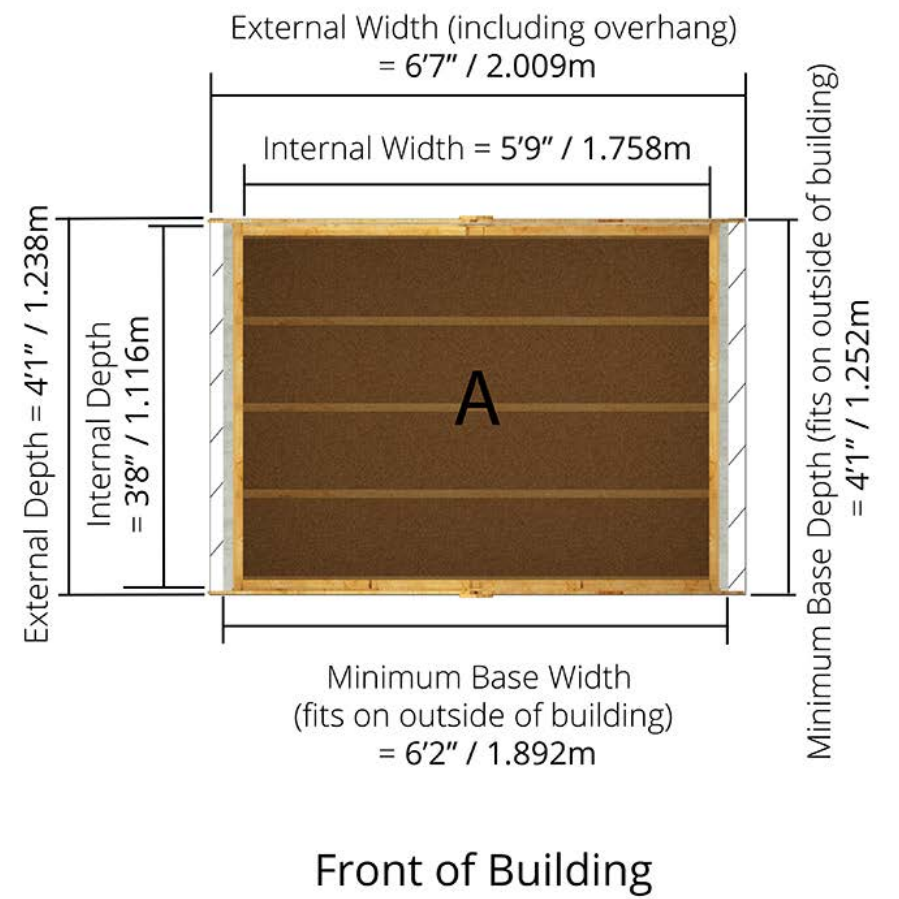

Floor Profile

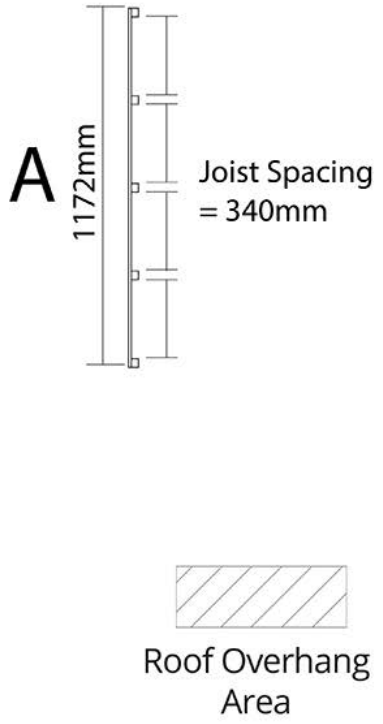

Please note: your base must be perfectly level and drainage is required to allow water to run off the surface. There must also be at least 2m clearance on each side to allow annual treatment to be applied.