

Metal Garden Shed

OWNER'S MANUAL / Instructions for Assembly Size 8' x 6'

Ver: 1.2

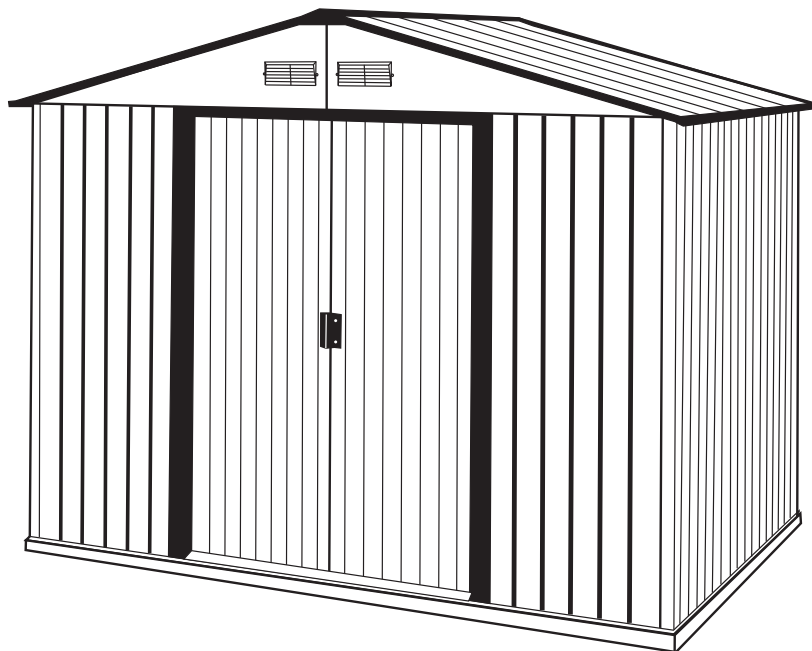

Customer
Service Hotline
(800) 483-4674
www.uspolymersinc.com

Requires two people and takes 2-3 hours for Installation.

- Tall Walk in Shed
- Quick & Easy Assembly
- Ridge Reinforced Walls
- Wide Double Doors
- Available in Various Sizes

Call us for any missing or damaged parts.
Do not return to the store.

Parts List



Note: Check all parts prior to installation.

ACCESSORIES

CODE	DESCRIPTION	QTY
BLB	BASE BAR BACK LEFT	1
BRB	BASE BAR BACK RIGHT	1
BSB	BASE BAR SIDE LEFT & RIGHT	2
BBF	BASE BAR FRONT LEFT & RIGHT	2
ECB	ENTRANCE TAPER CHANNEL	1
DCL	DOOR COLUMN PROFILE LEFT	1
DCR	DOOR COLUMN PROFILE RIGHT	1
ABLB	TOP ANGLE BACK LEFT	1
ABRB	TOP ANGLE BACK RIGHT	1
ASB	TOP ANGLE SIDE LEFT & RIGHT	2
SCB	SLIDING CHANNEL COVER	1
SSB	SLIDING CHANNEL SUPPORT	1
SLB	SLIDING CHANNEL LEFT	1
SRB	SLIDING CHANNEL RIGHT	1
RSB	ROOF SUPPORT LEFT & RIGHT	4
SB1B	ROOF SUPPORT BRACKET FRONT RIGHT / BACK LEFT	2
SB2B	ROOF SUPPORT BRACKET FRONT LEFT / BACK RIGHT	2
RF1B	ROOF FLASHING FRONT RIGHT / BACK LEFT	2
RF2B	ROOF FLASHING FRONT LEFT / BACK RIGHT	2
RF3B	ROOF FLASHING SIDE FRONT LEFT / BACK RIGHT	2
RF4B	ROOF FLASHING SIDE FRONT RIGHT / BACK LEFT	2
RFCB	ROOF FLASHING CENTER	2
TSLB	DOOR PANEL STRIP TOP LEFT	1
TSRB	DOOR PANEL STRIP TOP RIGHT	1
BSLB	DOOR PANEL STRIP BOTTOM LEFT	1
BSRB	DOOR PANEL STRIP BOTTOM RIGHT	1
DSS	DOOR PANEL STRIP SIDE LEFT & RIGHT	2
DSCB	DOOR PANEL STRIP CROSS	4
WCF	WALL PANEL CORNER FRONT LEFT & RIGHT	2
WCB	WALL PANEL CORNER BACK LEFT & RIGHT	2
WS	WALL PANEL SIDE	6
WFL	WALL PANEL FRONT LEFT	1
WFR	WALL PANEL FRONT RIGHT	1
GPLB	GABLE PANEL FRONT LEFT / BACK RIGHT	2
GPRB	GABLE PANEL FRONT RIGHT / BACK LEFT	2
GPS	GABLE PANEL SUPPORT	2
RP1B	ROOF PANEL FRONT LEFT / BACK RIGHT	2
RP2B	ROOF PANEL CENTER LEFT & RIGHT	2
RP3B	ROOF PANEL FRONT RIGHT / BACK LEFT	2
DPLB	DOOR PANEL LEFT	1
DPRB	DOOR PANEL RIGHT	1

CODE	DESCRIPTION	QTY
BS	BOTTOM SLIDER	4
DH	DOOR HANDLE	2
FC	FLASHING END CAP	2
TC	TOP CORNER	4
TS	TOP SLIDER	4
VC	VENTILATION COVER	4
PW	PLASTIC WASHER	191
PC	PLASTIC SCREW COVER	75
WST	WEATHER STRIPPING TAPE	2.8 MTR
S1	DIA. 4.2 x 10mm. (5/32" x 3/8")	202
S2	DIA. 4.2 x 16mm. (5/32" x 5/8")	28
S3	M4 x 10mm. (5/32" x 3/8")	76

PROFILES

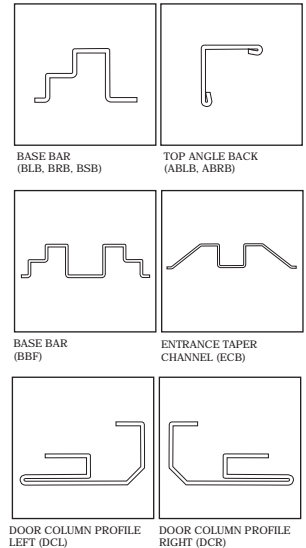

ACCESSORIES

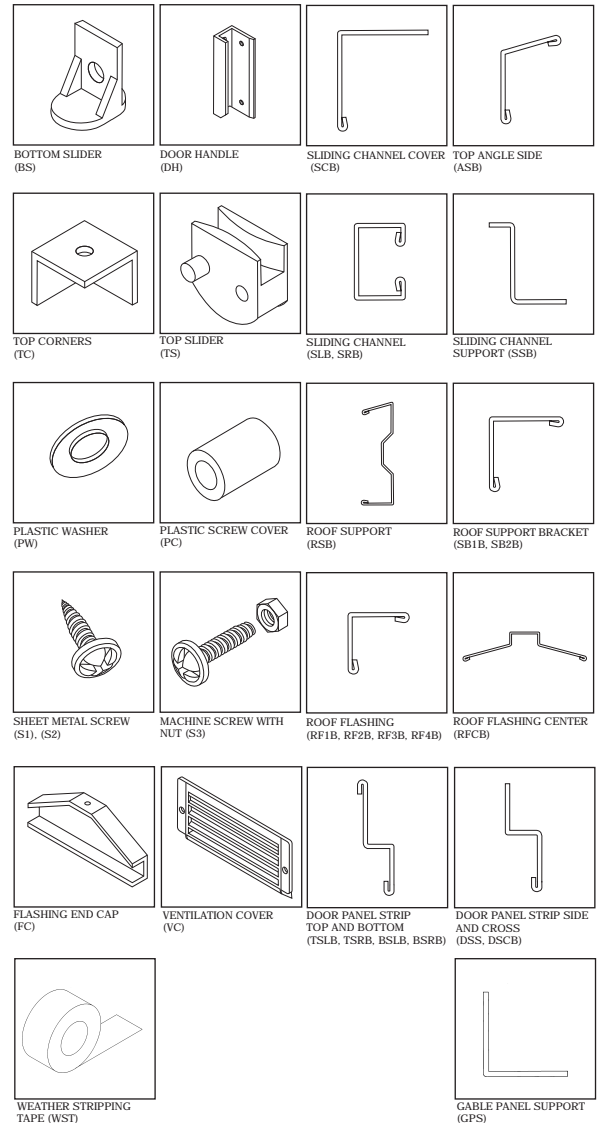

Tools You Will Need

- Hand Gloves
- Cordless Drill - Philips Head
- Screw driver - Philips Head
- Carpenters Square
- Eye Protector
- 8' Step Ladder
- Adjustable pliers
- Level - 3ft.
- Tape Measure

IMPORTANT: USE HAND GLOVES TO PREVENT INJURY.

Exploded View

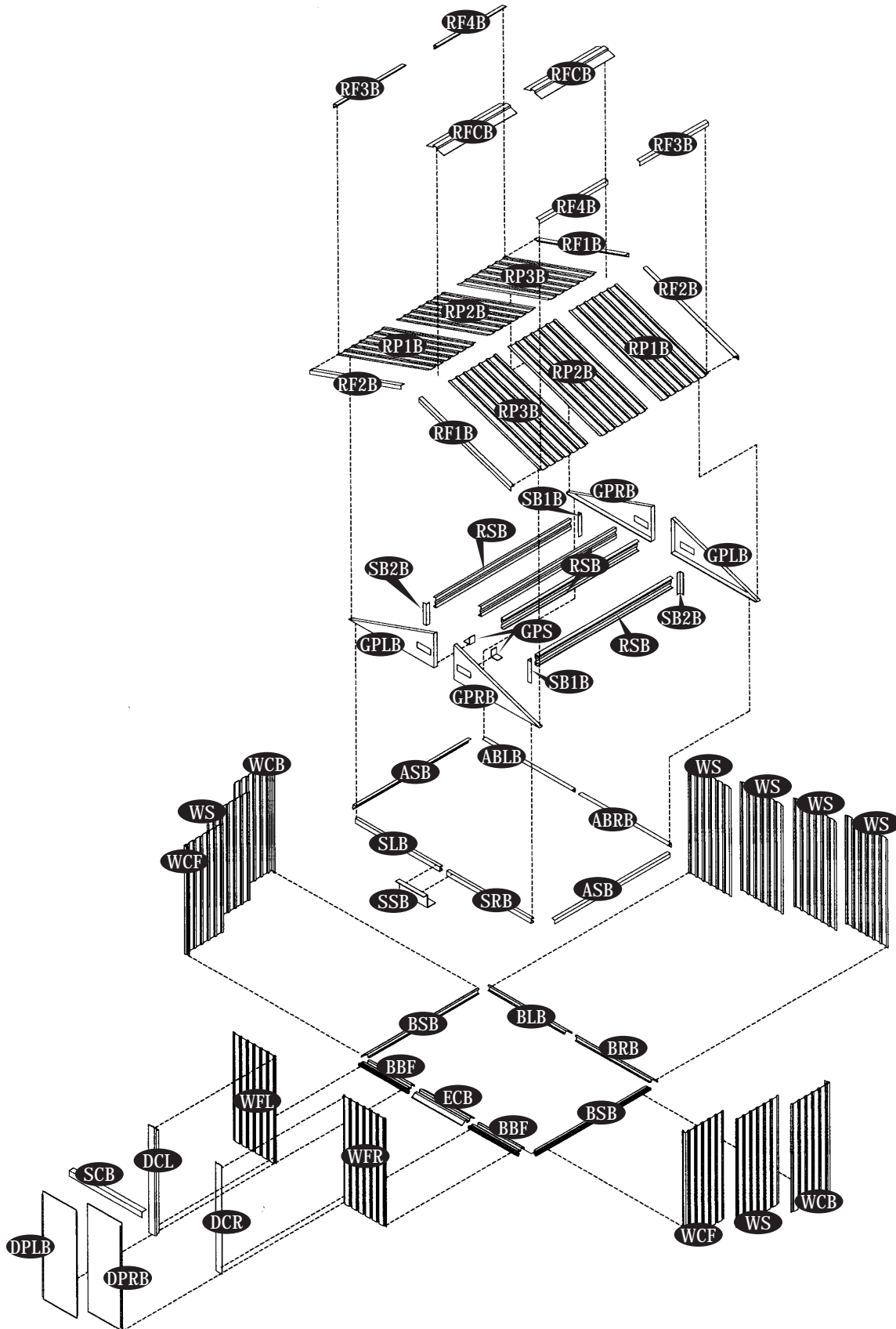

IMPORTANT: USE HAND GLOVES TO PREVENT INJURY.

Duramax Storage Shed Limited Fifteen Year Warranty

U.S. Polymer Inc. will send a replacement part free of charge, in the event of material defects and or workmanship for a period of fifteen years from the date of purchase.

This warranty is extended only to the original purchaser. A purchase receipt or other proof of date of original purchase will be required before warranty service is rendered. In no event shall we pay the cost of flooring, labor, installation or any other costs related thereto.

This warranty only covers failures due to defects in material or workmanship which occurs during normal use and does not extend to color change arising due to normal weathering or to damage resulting from misuse or neglect, commercial use, failure to follow assembly instructions and the owner's manual (including proper anchoring of the shed), painting, forces of nature and other causes which is beyond our control.

Claims under this warranty must be made within the warranty period by calling 1-800-483-4674 or mail in a dated sales slip and clear photograph of the part to:

U.S. Polymers, Inc.
6915 Slauson Avenue
Commerce, CA 90040

We reserve the right to discontinue or change components. If a component has been discontinued or is not available,

U.S. Polymers, Inc. reserves the right to substitute a component of equal quality as may be compatible.

Limits and Exclusions

There are no express warranties except as listed above. The warrantor shall not be liable for incidental or consequential damages resulting from the use of this product, or arising out of any breach of this warranty.

All express warranties are limited to the warranty period set forth above. Some states do not allow the exclusion or limitation on how long an implied warranty lasts, so the above limitations may not apply to you.

This warranty gives you specific legal rights and you may also have other rights which vary from state to state or country to country.

IMPORTANT: USE HAND GLOVES TO PREVENT INJURY.

A. Foundation & Base Frame

Note: It is important that these instructions are followed step by step.

DuraMax must be installed on a level wooden platform or a level concrete foundation.

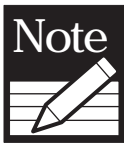

Wooden platform is extra and is not included. Don't install under windy conditions.

Wooden Platform (Not Included)

The following are a list of lumber and sizes you will need.

Pressure Treated - Wood Studs:

4ea 2" x 4" x 91 1/2" (50mm x 101.6mm x 2324.1mm)

3ea 2" x 4" x 70" (50mm x 101.6mm x 1778mm)

Exterior Grade (CDX) - 3/4" (19mm) plywood

1ea 3/4" x 48" x 96" (19mm x 1220mm x 2440mm)

1ea 3/4" x 22" x 96" (19mm x 558mm x 2440mm)

1ea 3/4" x 6" x 70" (19mm x 152.4mm x 1778mm)

L-Brackets: 4ea

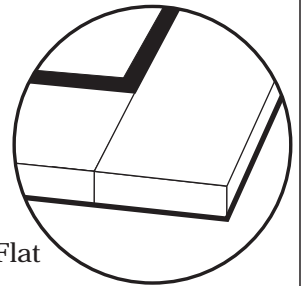

Lay 50mm x 88.9mm Flat

Parts needed:

- | | |
|---------------------------------|-------|
| (1) Base bar back left | (BLB) |
| (1) Base bar back right | (BRB) |
| (2) Base bar side left & right | (BSB) |
| (2) Base bar front left & right | (BBF) |
| (1) Entrance taper channel | (ECB) |
| (20) Sheet metal screws | (S1) |
| (12) Sheet metal screws | (S2) |

1. Use pressure treated wood studs 2"x 4" (50mm x 101.6mm) to create a platform frame that has an outside dimension of 70" x 102" (1778mm x 2590mm).

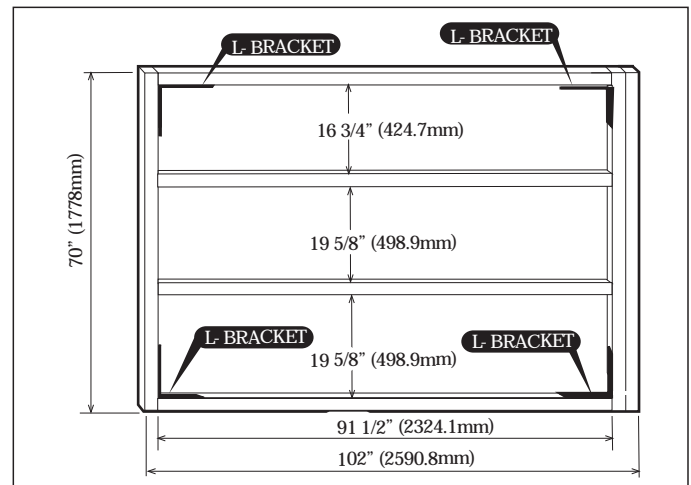

2. Using exterior grade CDX 3/4" (19mm) plywood, cut and fit together the sheets to form solid foundation as shown. Foundation must be square and level.

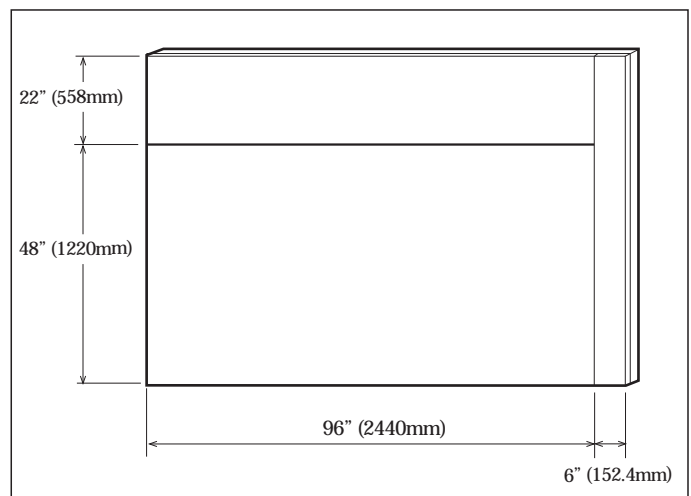

3. Assemble base bar back left (BLB) and base bar back right (BRB) with four (S1) screws.
See fig. 1 & 2.

Note *Take care of sharp edges.*

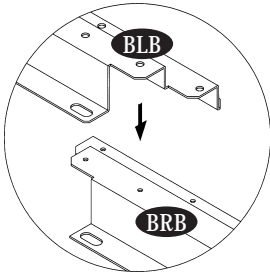

Fig.1

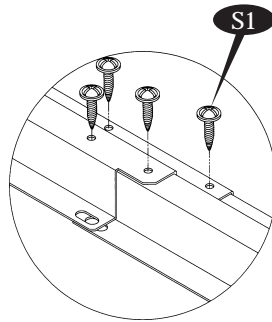
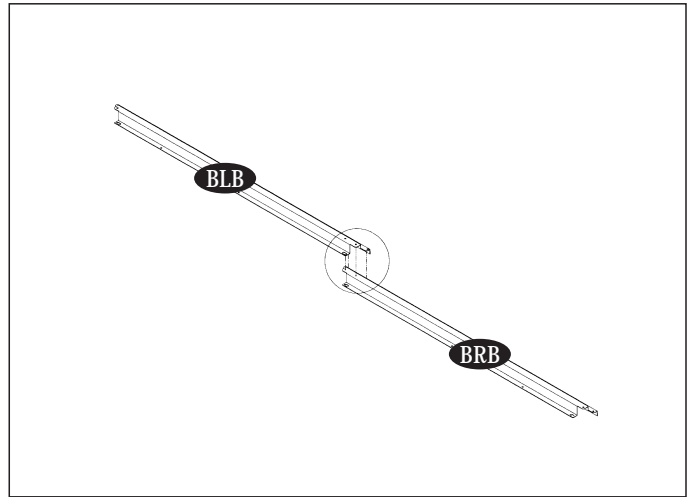
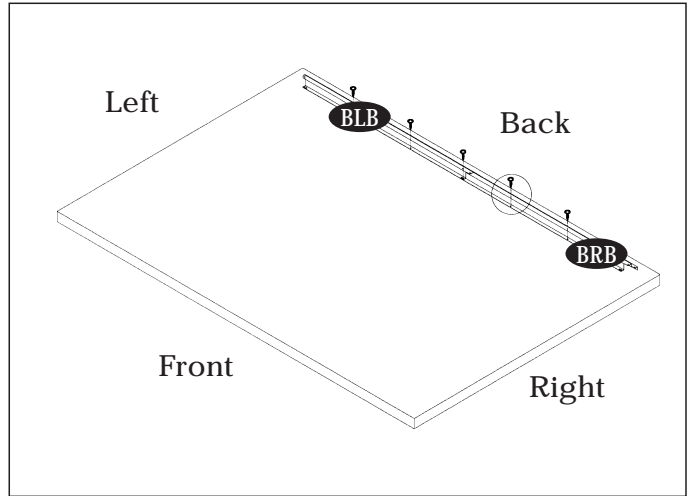
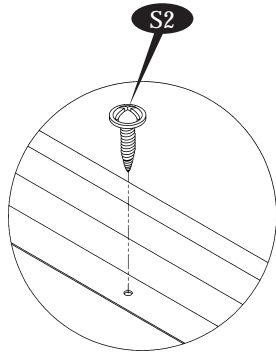

Fig.2



4. Place the base bar assembly on top of the foundation. Use (S2) screws to fix the assembly to foundation.



5. Insert the base bar side (BSB) into (BLB) & (BRB) secure with two (S1) screws on both sides.
See blowup.

Step 1

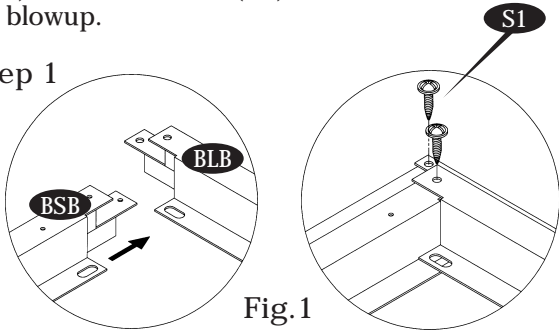

Fig.1

Step 2

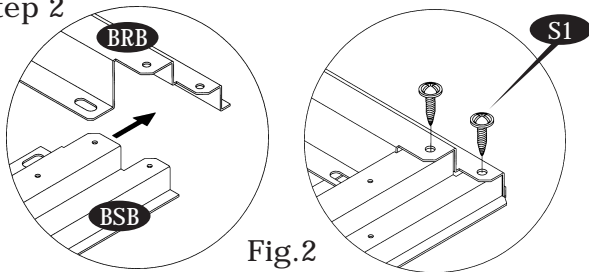
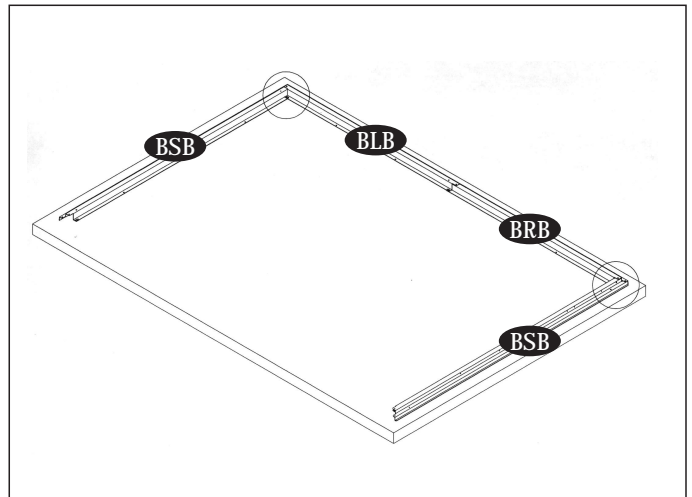
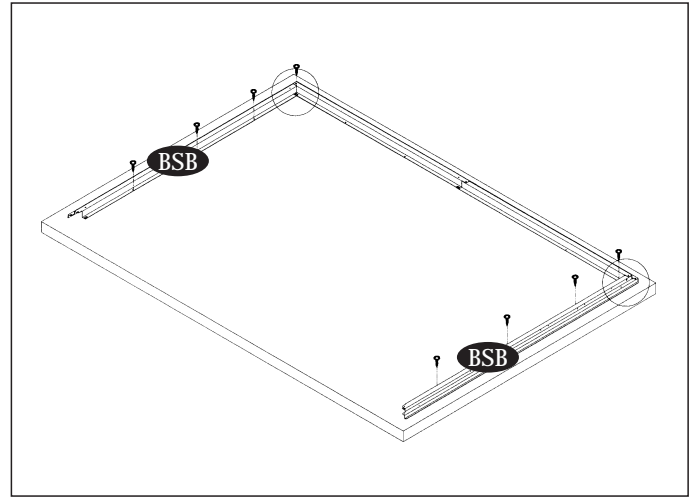
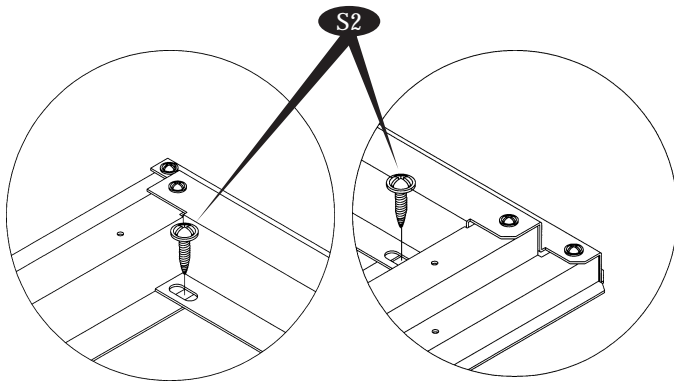

Fig.2



6. Using a carpenter square, line up the corners. Secure the base (BSB) to the foundation with (S2) screws. See blowup.



7. Place the base bar (BBF) on top of (BSB) on both sides. Secure with (S1) screw to (BSB) on both corners. See fig. 1 & 2.

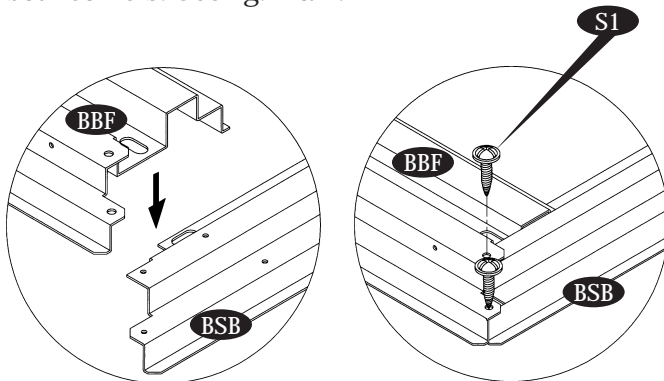
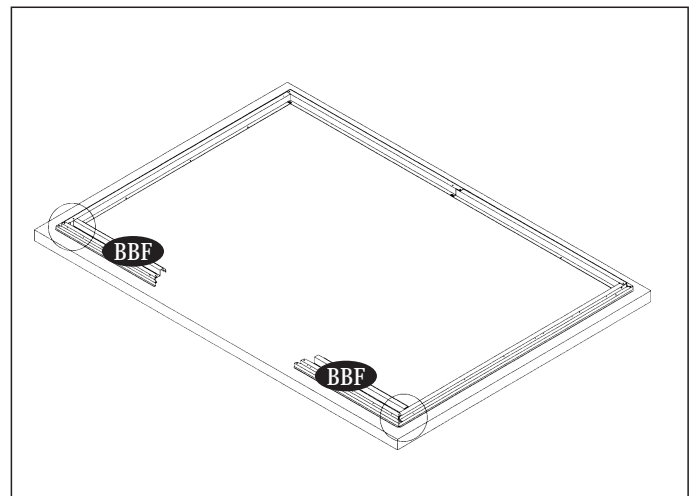
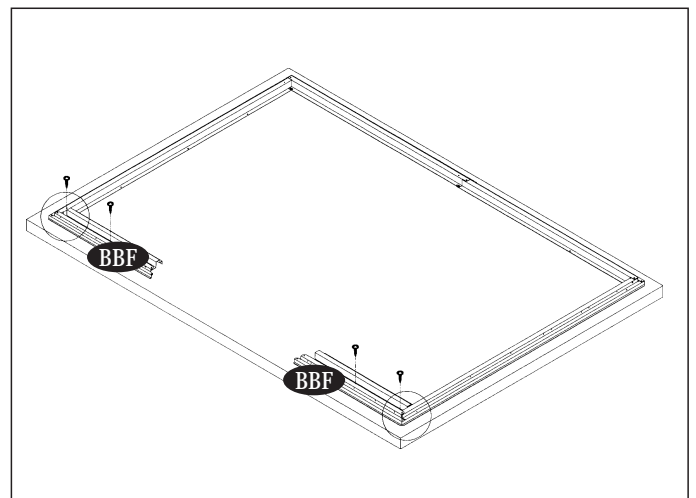
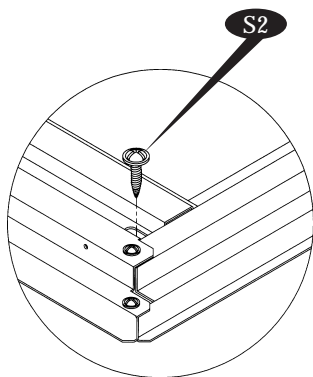

Fig.1

Fig.2



8. Using the carpenter square, line up the corners. Secure the base (BBF) to the foundation with (S2) screws.



9. Place the entrance taper channel (ECB) on top of the (BBF). Secure with (S2) screws to the foundation. See fig. 1 & 2.

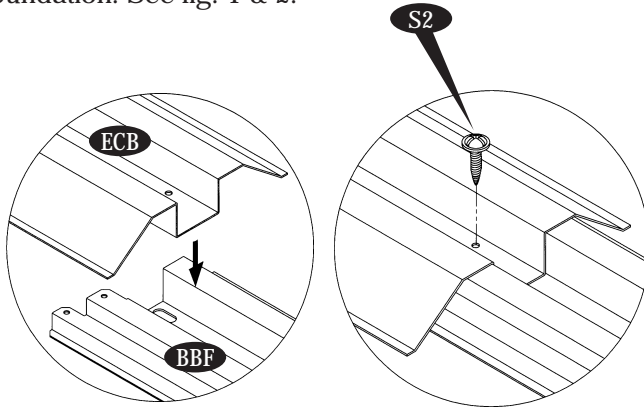
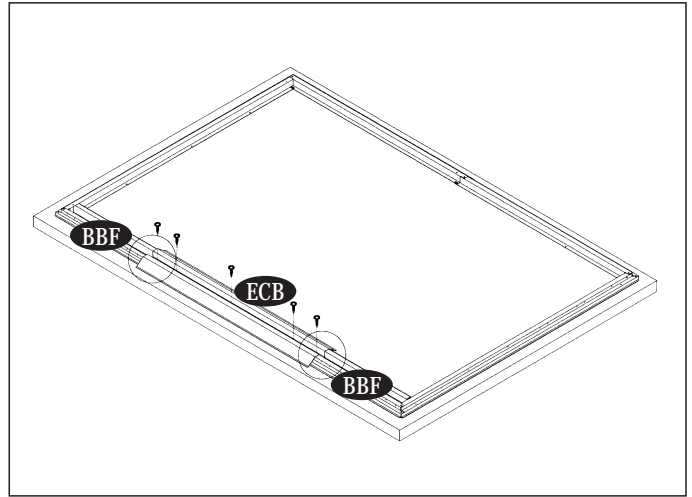

Fig.1

Fig.2



10. Measure in all direction as shown in figure. Make the base bar assembly in a perfect square.

Concrete foundation

10a. (Concrete foundation) Using a carpenter's square, line up corners. Align Base bars, mark the concrete at the holes in the base and drill concrete with 1/4" (dia. 6mm) concrete bit to accept anchor bolts to a 1 3/4" (44mm) depth. Replace base and secure with 1/4" x 1 3/8" (M6 x 35mm) anchor bolts (not provided).

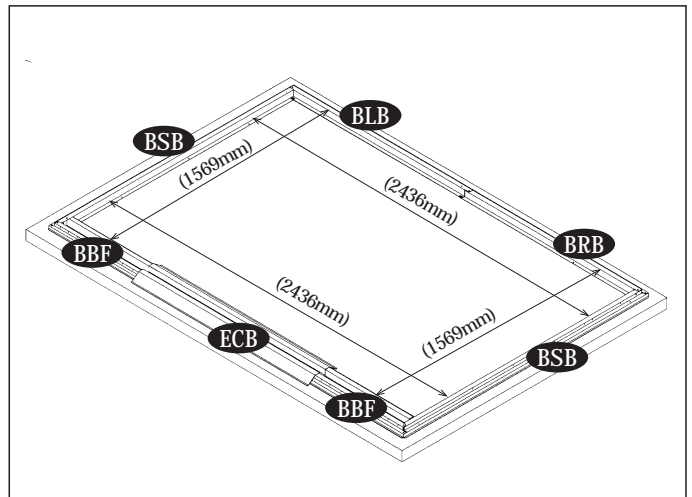

B. Walls & Columns

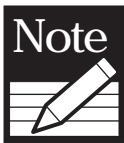

All panels are clearly marked and care should be taken to use the correct one.

Parts Needed:

- | | | | |
|--|-------|---------------------------------|--------|
| (1) Wall panel front right | (WFR) | (2) Top angle side left & right | (ASB) |
| (1) Wall panel front left | (WFL) | (1) Sliding channel support | (SSB) |
| (2) Wall panel corner front left & right | (WCF) | (1) Sliding channel cover | (SCB) |
| (2) Wall panel corner back left & right | (WCB) | (4) Top slider | (TS) |
| (6) Wall panel side | (WS) | (1) Door column profile left | (DCL) |
| (1) Sliding channel right | (SRB) | (1) Door column profile right | (DCR) |
| (1) Sliding channel left | (SLB) | (1) Top angle back left | (ABLB) |
| | | (1) Top angle back right | (ABRB) |
| | | (83) Plastic washer | (PW) |
| | | (87) Sheet metal screw | (S1) |
| | | (10) Machine screw | (S3) |

1. Place the wall panel (WFR) on the base bar (BBF). Front right side of the shed line up the holes with base bar. Secure with (S1) screws with washers from outside.

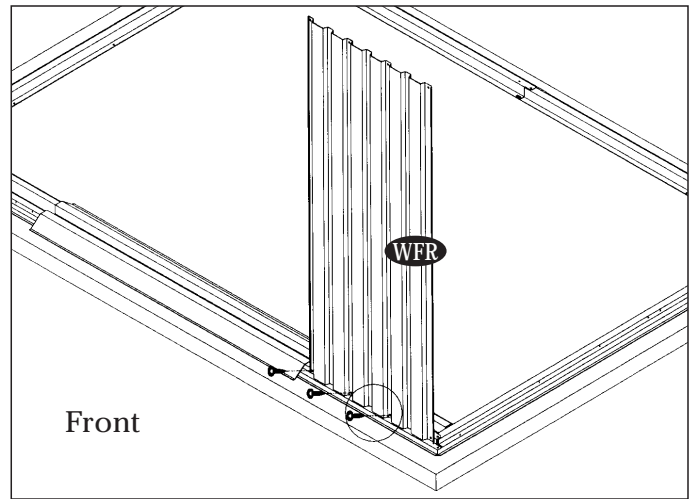
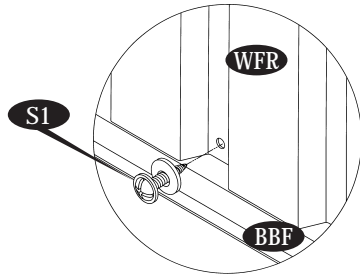

2. Place the wall panel corner front (WCF) on the base bar (BSB). Line up the holes with base bar and use (S1) screws with washers to Secure.

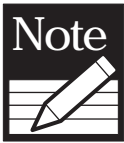

Make sure the overlapping position is as shown in fig.1

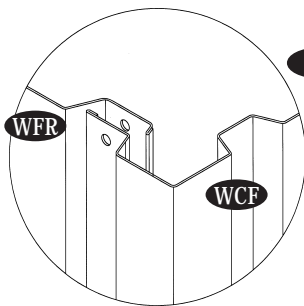

Fig.1

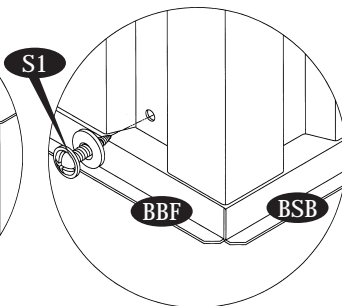
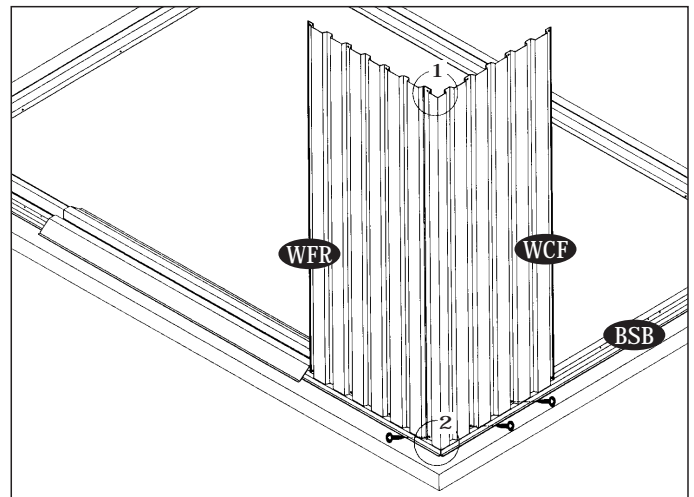
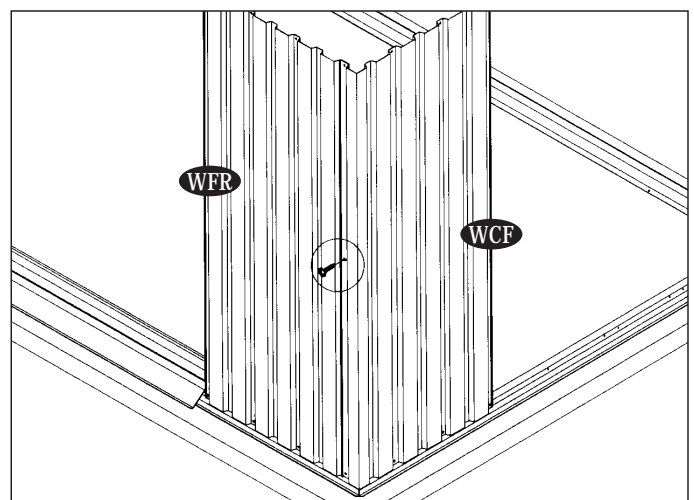
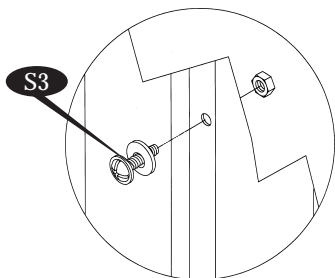

Fig.2



3. Use (S3) bolt and nut with washers to join together the wall panels.



4. Place the sliding channel right (SRB) on top of the wall panel (WFR) from inside. See the position in fig.1. Line up the holes with wall panel. Use (S1) screws with washers to fix. See fig.2

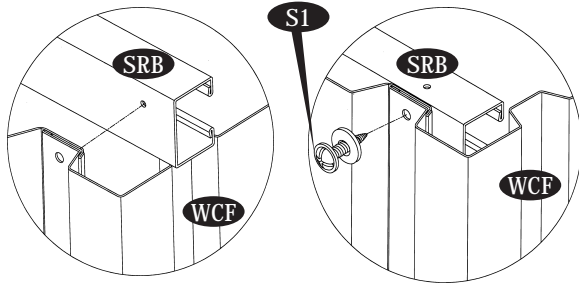
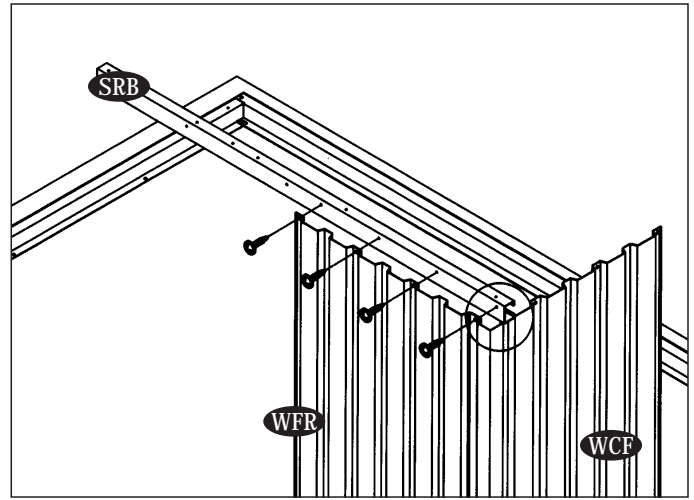
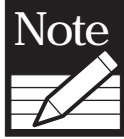

Fig.1

Fig.2



5. Insert the 2 pieces of (TS) Top slider into the sliding channel. See blowup.



Note Make sure the position of the projection on (TS) towards inside.

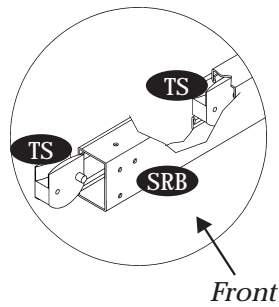

Front

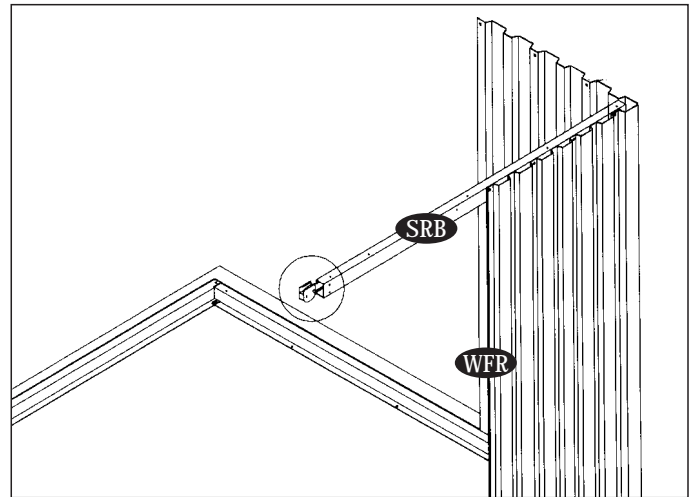

6. Place the wall panel (WFL) on the base bar (BBF). Front left side of the shed. Line up to holes with base bar. Secure with (S1) screws with washers from outside.

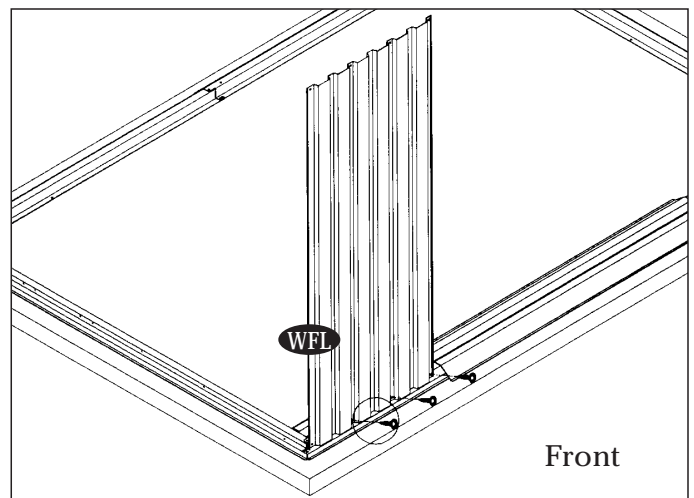
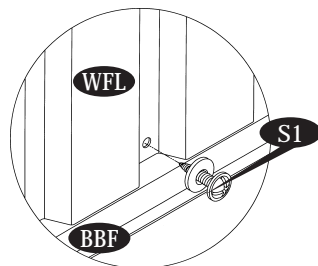

Front

7. Place the wall panel corner front (WCF) on the base bar (BSB). Line up the holes with base bar and use (S1) screws with washers to secure.

Note *Make sure the overlapping position is as shown in fig.1*

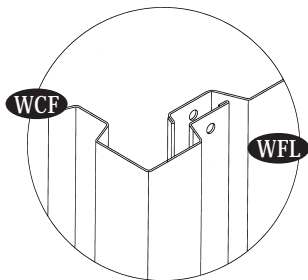

Fig.1

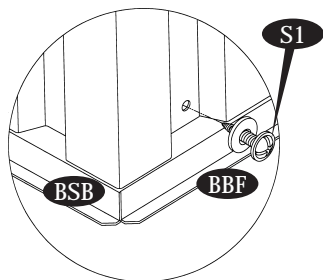
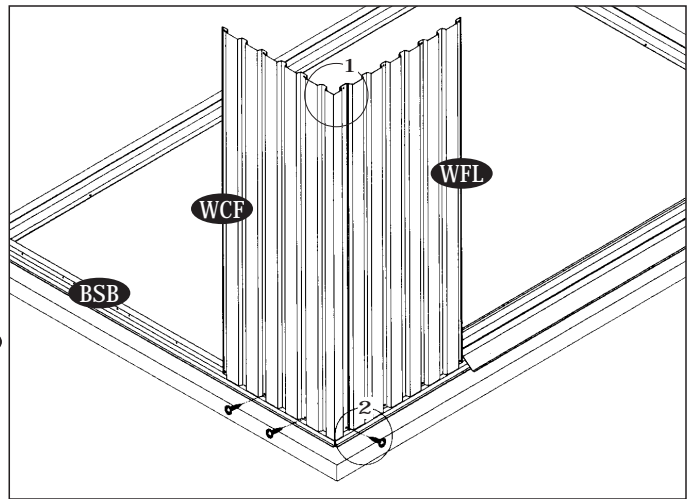
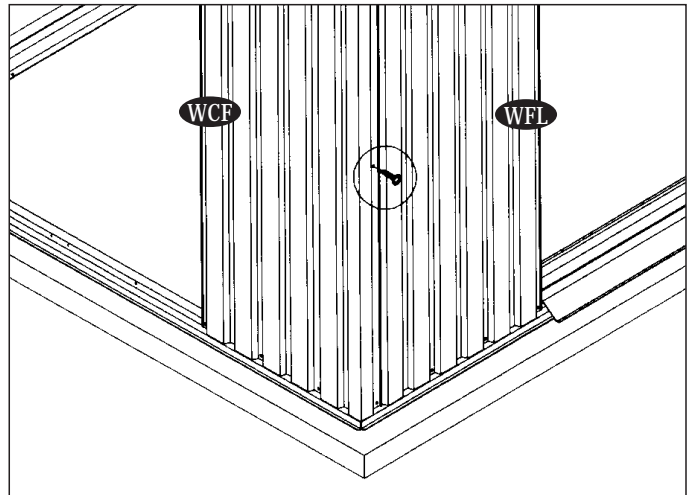
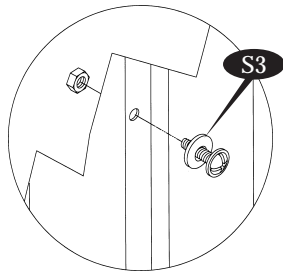

Fig.2



8. Use (S3) bolt and nut with washer to join together the wall panels.



9. Place the sliding channel left (SLB) on top of the wall panel (WFL) from inside. See the position in fig1. Line up the holes with wall panel use (S1) screws with washers to fix. See fig. 2

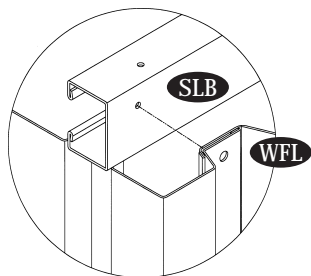

Fig.1

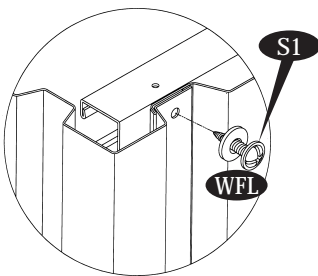
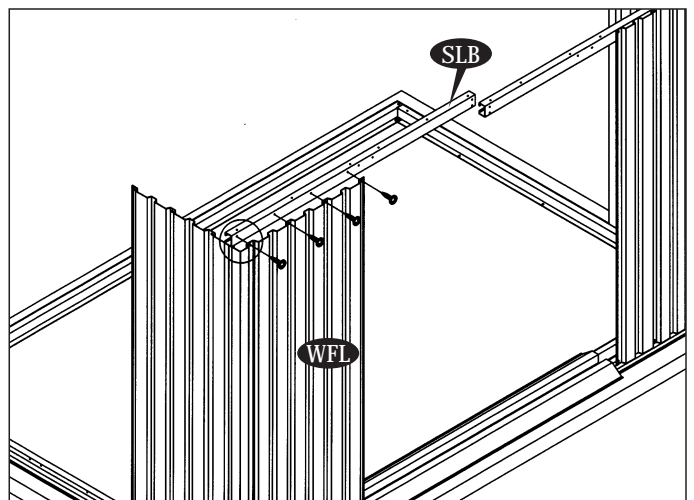
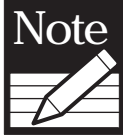

Fig.2



10. Insert the 2 pieces of (TS) Top slider into the sliding channel. See blowup.



Make sure the position of the projection on top slider towards inside.

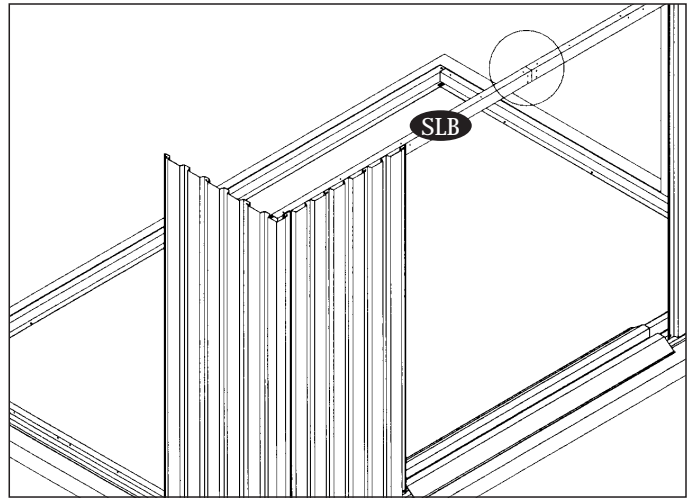
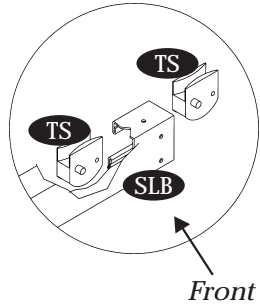

11. Place the sliding channel support (SSB) on the sliding channel (SLB) & (SRB). See fig.1. Align the holes with sliding channels and secure with (S1) screws. See fig. 2.

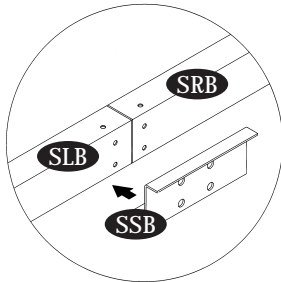

Fig.1

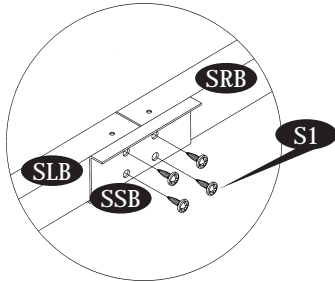
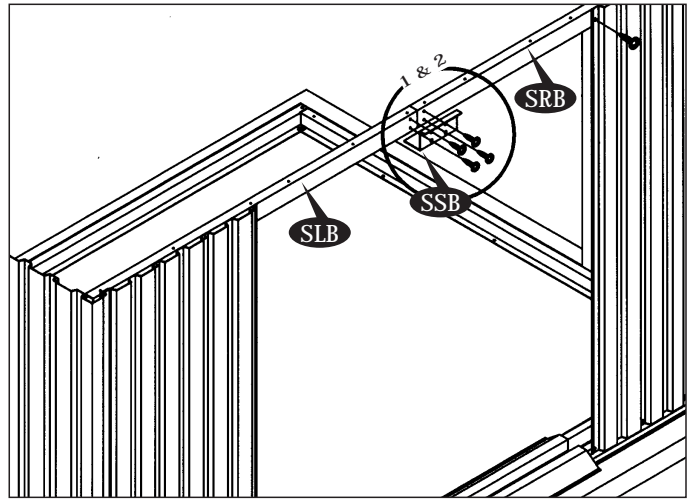
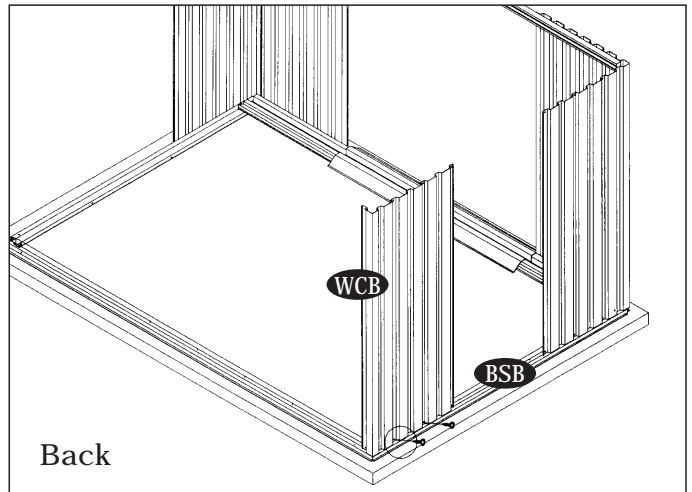
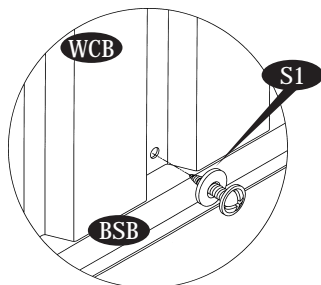

Fig.2



12. Place the wall panel corner back (WCB) on the base bar (BSB). Line up the holes with base bar and use (S1) screws with washers to secure.



Back

13. Assemble the center band (CBIP) with column fitting (CFP). Secure with (S1) screws at one end. Make 2 Sets.

Note *Make sure the overlapping position is as shown in fig.2.*

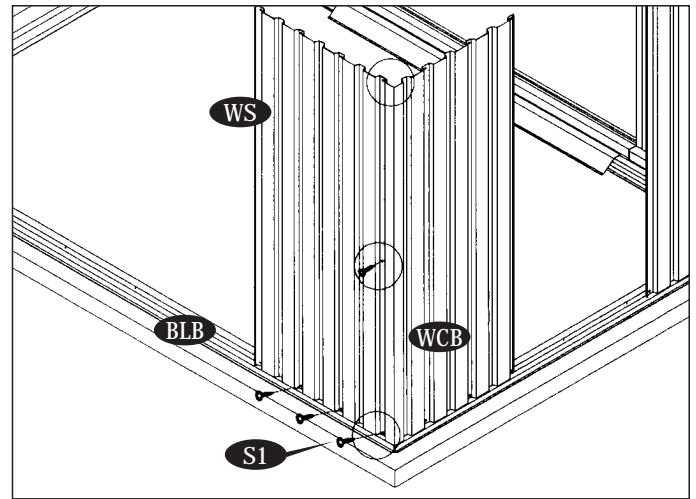
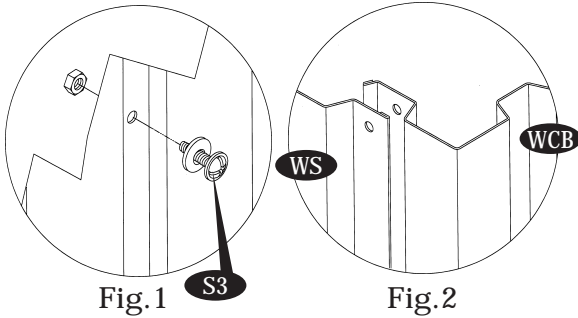

14. Place the top angle back left (ABLB) on top of the wall panel (WS) from inside. See the position in fig.1. Line up holes with wall panel. Use (S1) screws with washers to fix. See fig. 2

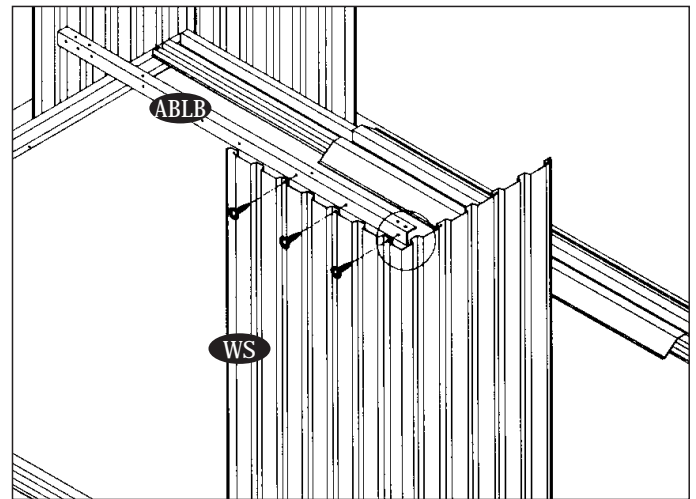
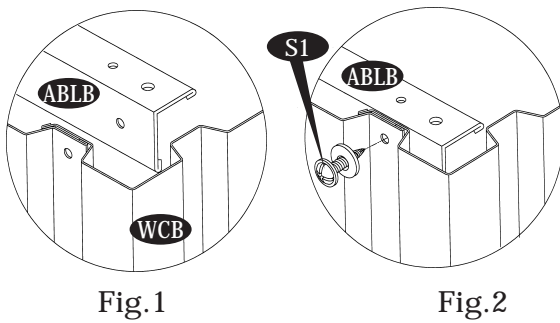

15. Place the top angle side (ASB) on top of the wall panels (WCB) & (WCF) and top angle (ABLB). Line up the holes and secure with (S1) screws with washers. See fig.1 & 2.

Note *Top angle (ASB) must sit on top angle (ABLB).*

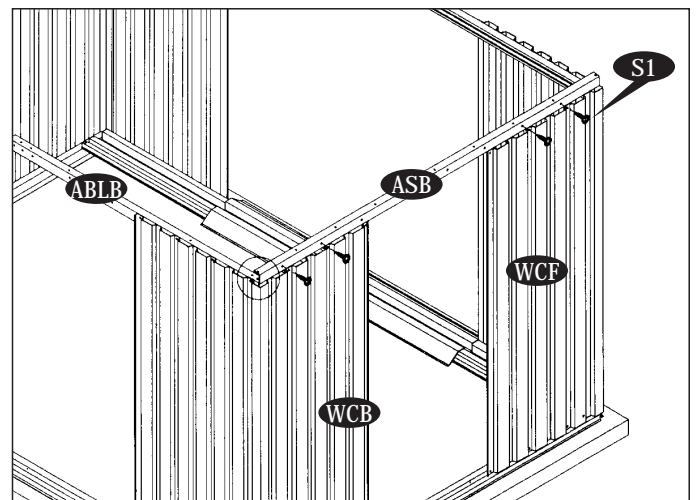
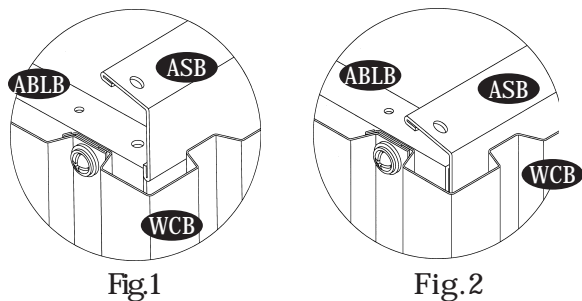

16. Place the wall panel (WS) on top of the base bar (BSB) and over lap with corner panels. Secure the wall panel to top angle and base bar with (S1) screws with washers.

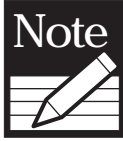

Make sure the overlapping position of panels is as shown in fig. 1 & 2.

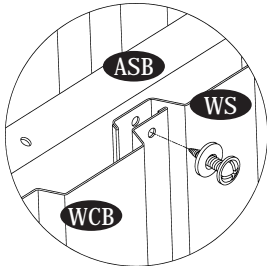

Fig.1

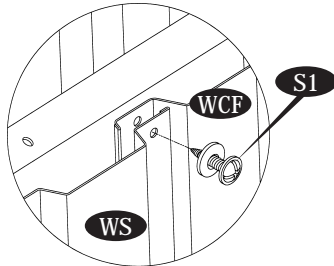
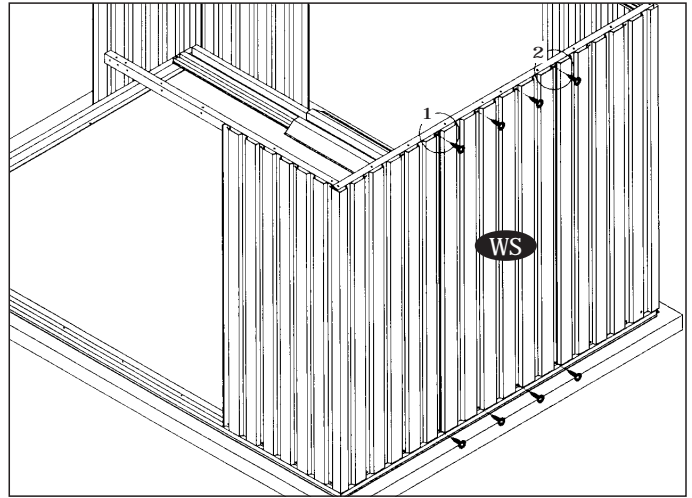
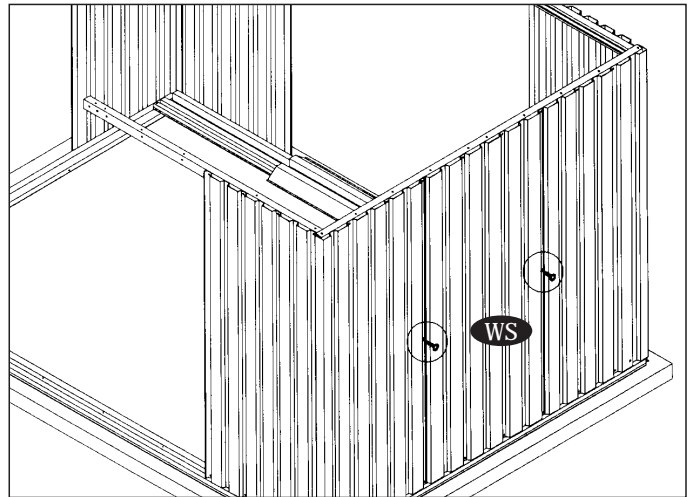
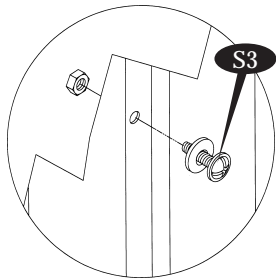

Fig.2



17. Use (S3) bolt & nut with washer to join together the middle of the wall panels.



18. Place the wall panel corner back (WCB) on the base bar (BSB). Line up the holes with base bar and use (S1) screws with washers to secure.

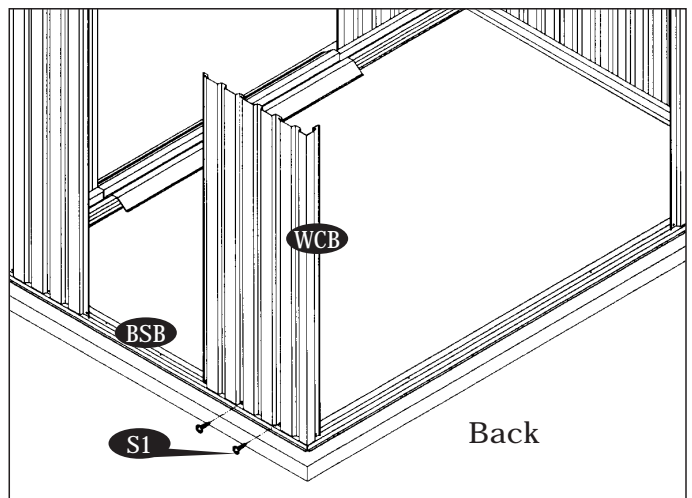

19. Place the wall panel (WS) on the base bar (BRB). Line up the holes with base bar and use (S1) screws with washers to secure. Use (S3) bolt and nut with washer to join together in the middle of the wall panel. See fig. 2.

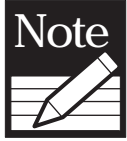

Make sure the overlapping position of panels is as shown in fig. 1.

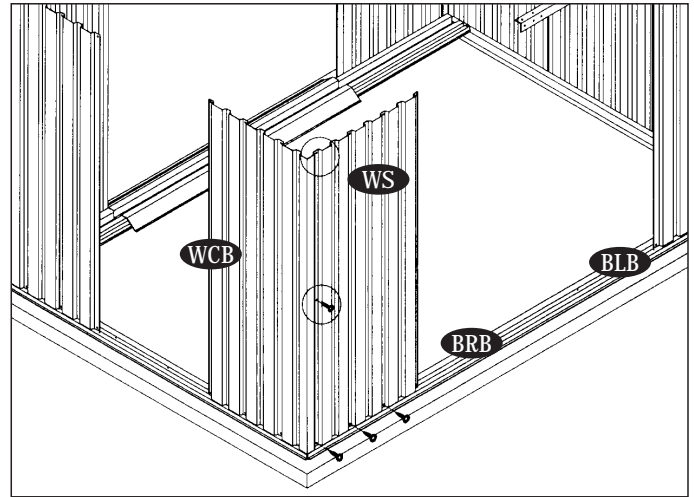
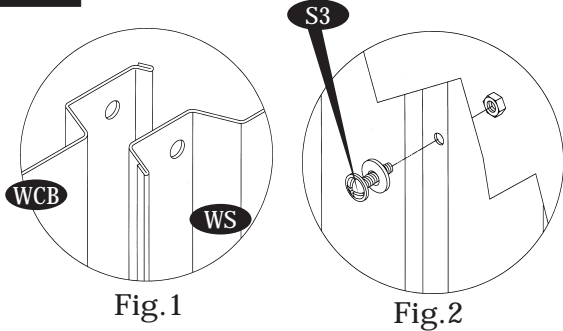

20. Place the top angle back right (ABRB) on top of the wall panel (WS) from inside. See the position in fig.1. Line up the holes with wall panel use (S1) screws with washers to secure. See fig. 2

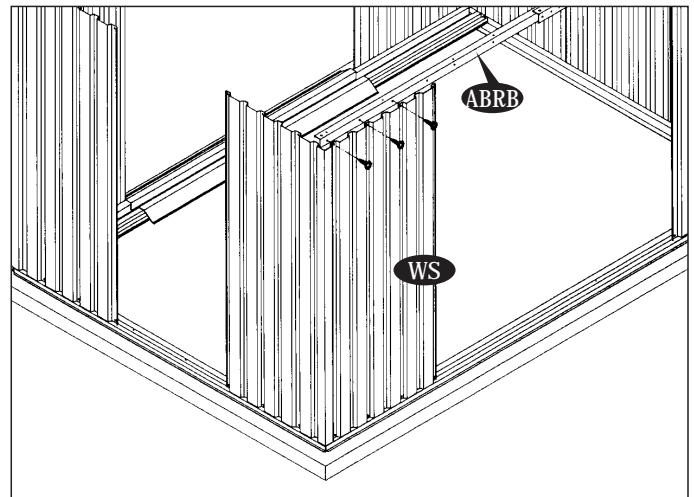
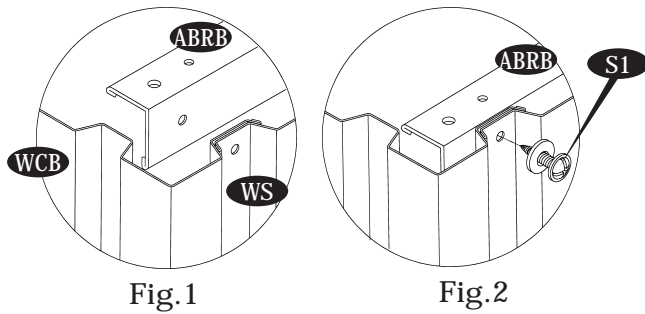

21. Join top angle back left & right (ABLB) & (ABRB) together with (S1) screws. See blowup.

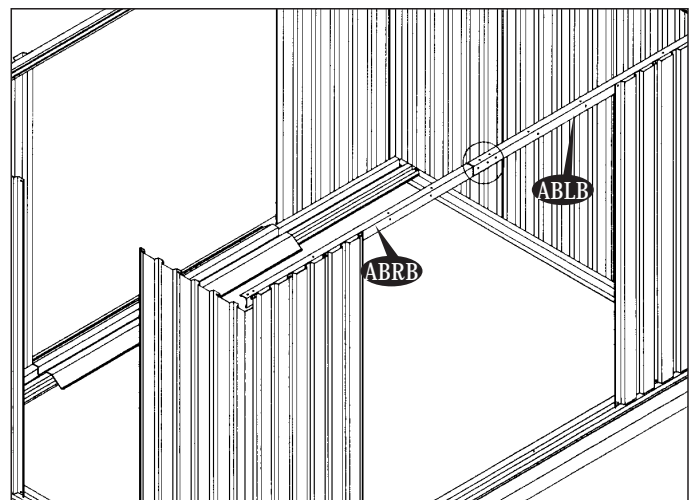
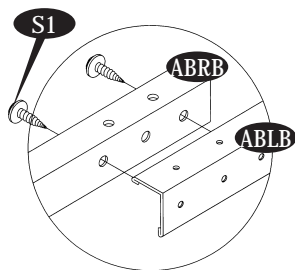

22. Place the top angle side (ASB) on top of the wall panels (WCF) & (WCB) from inside. Line up the holes with panels and secure with (S1) screws with washers.

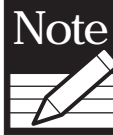

Top angle (ASB) must sit on top angle (ABRB)

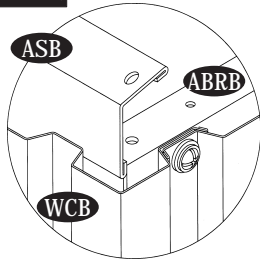

Fig.1

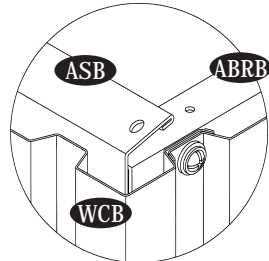
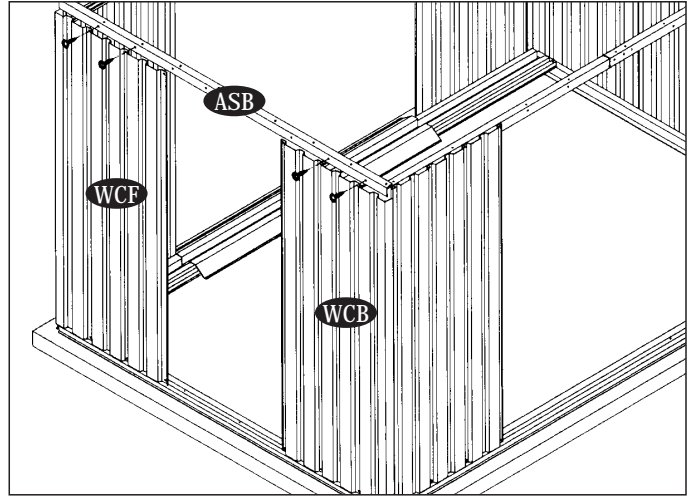

Fig.2



23. Place the wall panel (WS) on top of base bar (BSB) and overlap with corner panels. Secure the wall panel to top angle and base bar with (S1) screws with washers. Use (S3) bolt and nut with washer to join together in middle of the wall panel. See fig. 3.



Make sure the overlapping of the panels. See fig. 1 & 2.

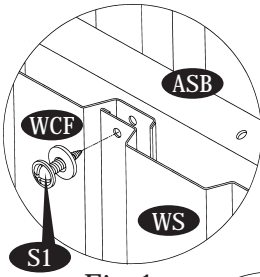

Fig.1

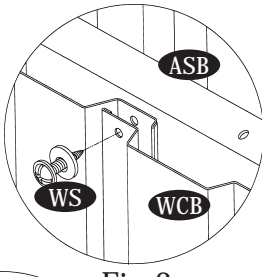

Fig.2

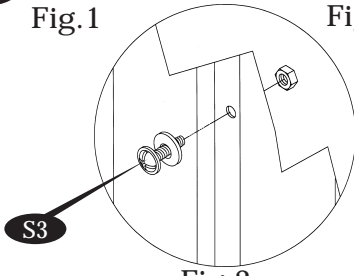
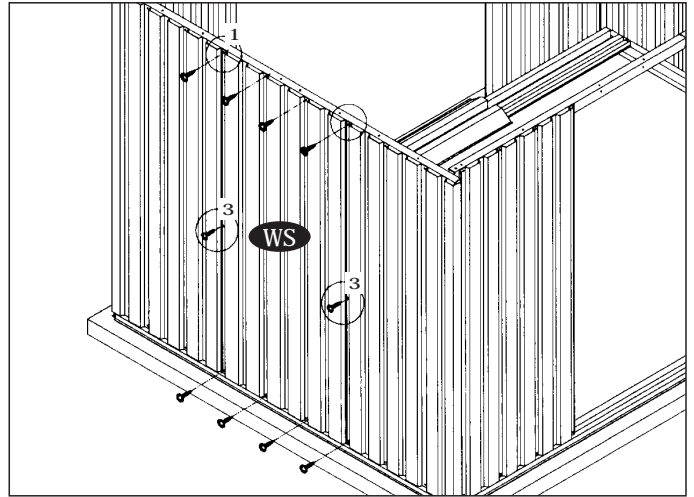

Fig.3



24. Place the wall panel (WS) on the base bar and secure with (S1) screws with washers to base bar & top angle. Use (S3) bolt and nut with washer to join together in middle of the wall panel. See fig. 2.



Make sure the overlapping position. See fig. 1.

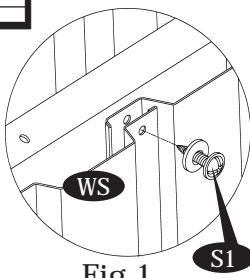

Fig.1

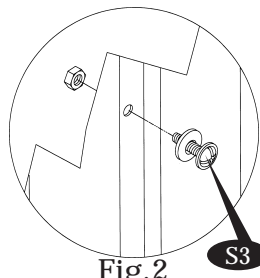
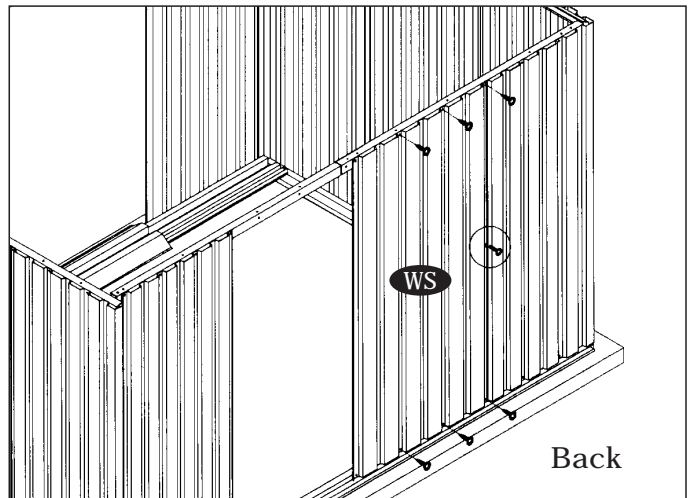
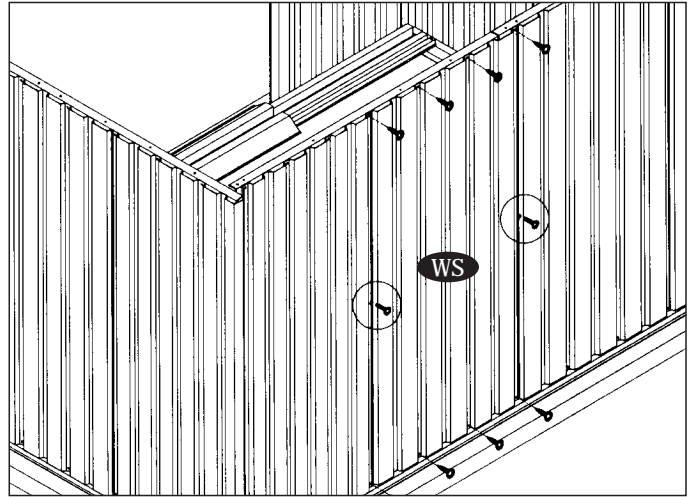
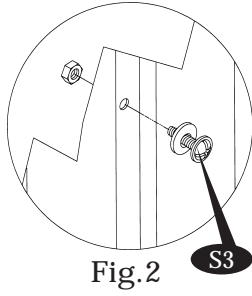
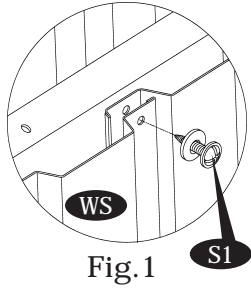

Fig.2



Back

25. Follow the same way as item No.24



26. Place the left door column (DCL) on top of the base bar (BBF) and insert into the wall panel. See Blowup.

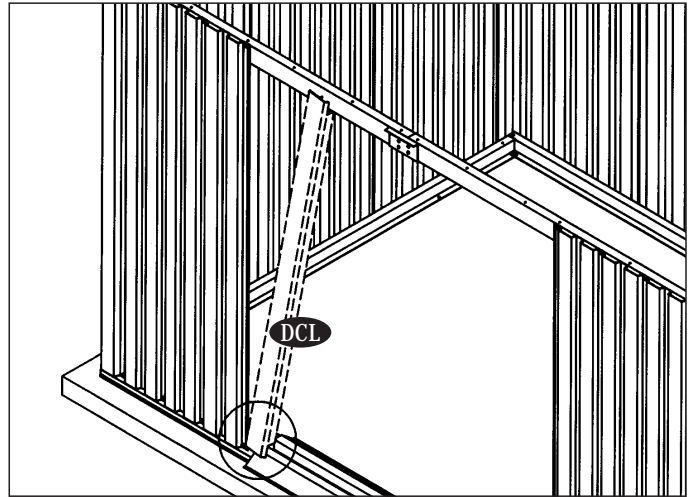
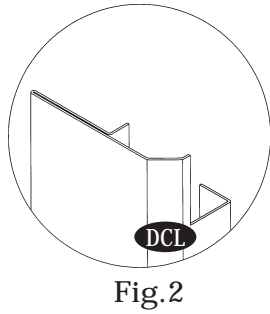
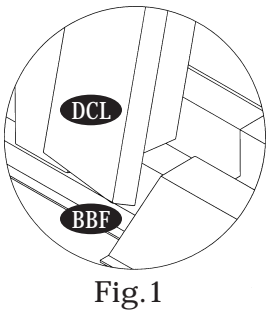

27. Secure the door column with (S1) screws. Repeat the same for the right door column (DCR).

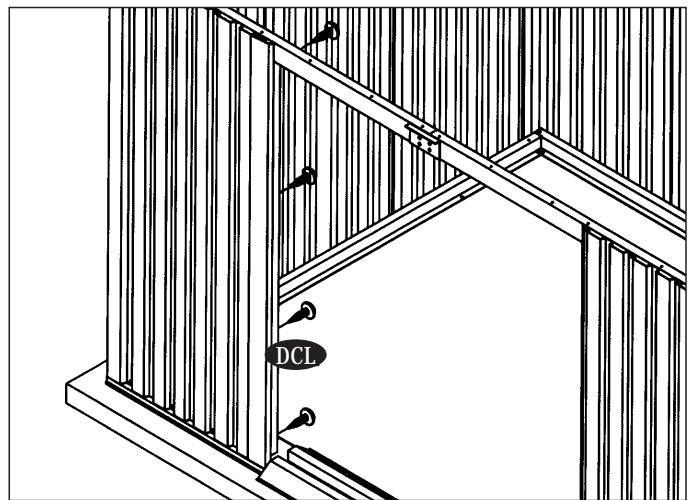
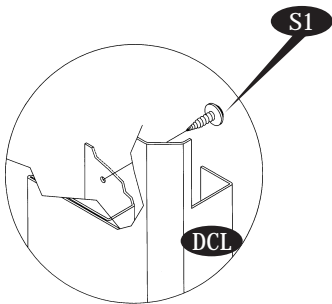

28. Place the sliding channel cover (SCB) on top of the sliding support (SSB). Secure with two (S1) screws. See blowup.

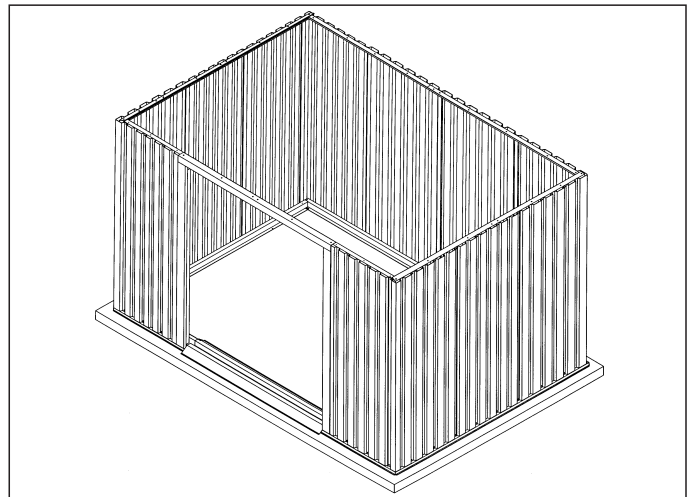
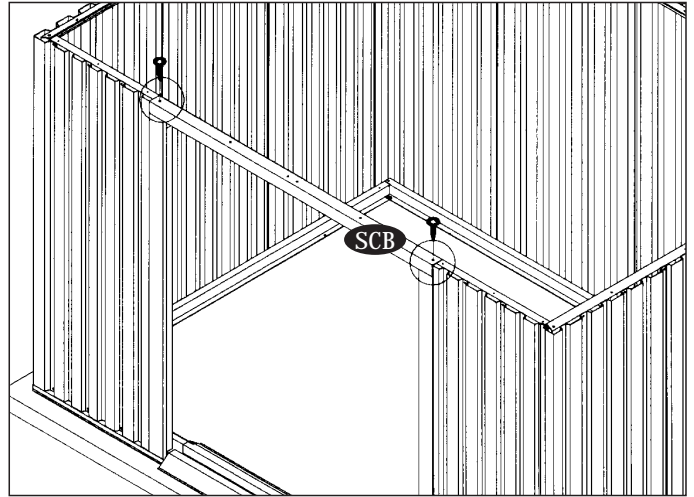
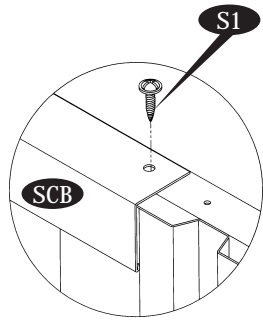

C. Roof

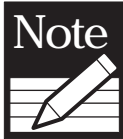

All parts are clearly marked and care should be taken to use the correct one.

Parts Needed:

(2) Gable panel front left / back right	(GPLB)	(2) Roof flashing side front left / back right	(RF3B)
(2) Gable panel front right / back left	(GPRB)	(2) Roof flashing side front right / back left	(RF4B)
(2) Gable panel support	(GPS)	(2) Roof flashing center	(RFCB)
(2) Roof support bracket front right / back left	(SB1B)	(2) Flashing end cap	(FC)
(2) Roof support bracket front left / back right	(SB2B)	(2.8m) Weather Stripping Tape	(WST)
(4) Roof support left & right	(RSB)	(4) Ventilation cover	(VC)
(2) Roof panel front left / back right	(RP1B)	(4) Top corners	(TC)
(2) Roof Panel center left and right	(RP2B)	(98) Plastic washers	(PW)
(2) Roof panel front right / back left	(RP3B)	(98) Sheet metal screw	(S1)
(2) Roof flashing front right / back left	(RF1B)	(4) Sheet metal screw	(S2)
(2) Roof flashing front left / back right	(RF2B)	(41) Machine screw with nut	(S3)



Note Remove the Polyethylene Film before assembling.

1. Place the Gable panel (GPRB) on top of the sliding channel (SRB). See fig.1. Push the Gable panel inside the top angle side (ASB). See fig.2. Align the holes with sliding channel and secure with (S1) screws from inside.

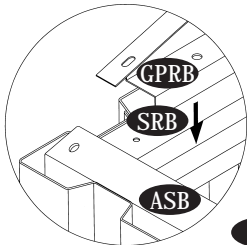

Fig.1

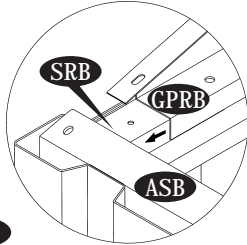

Fig.2

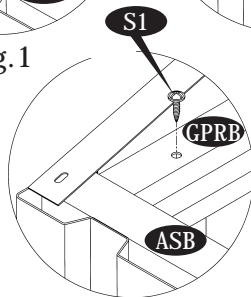
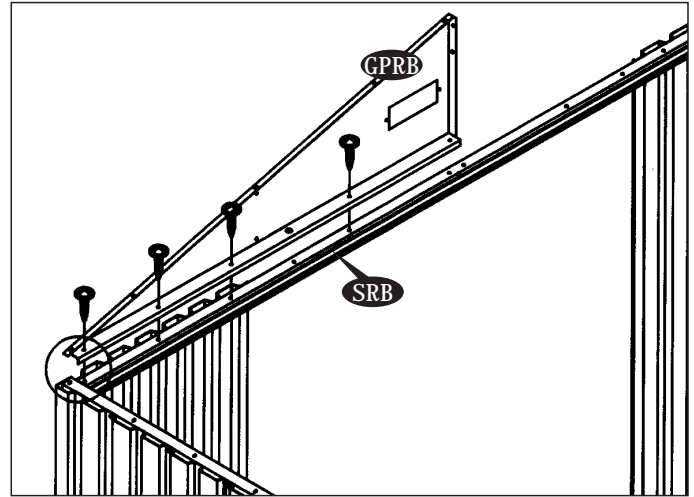
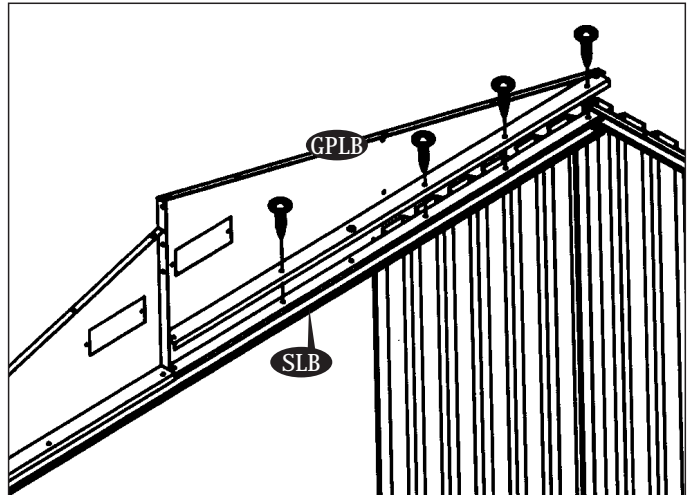

Fig.3



2. Place the Gable Panel (GPLB) on top of the sliding channel (SLB). Insert the Gable panel inside the Top angle side (ASB). Align the holes with sliding channel and secure with (S1) screws from inside.



3. Assemble the Gable Panel (GPLB) & (GPRB) together with GPS see fig.1 & 2

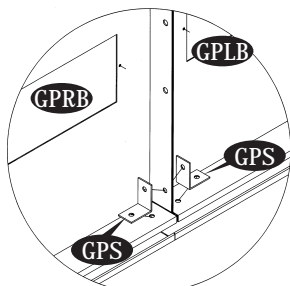

Fig.1

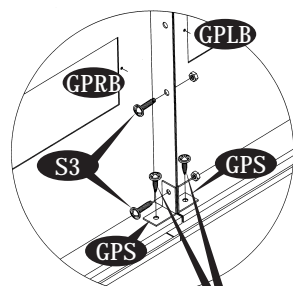
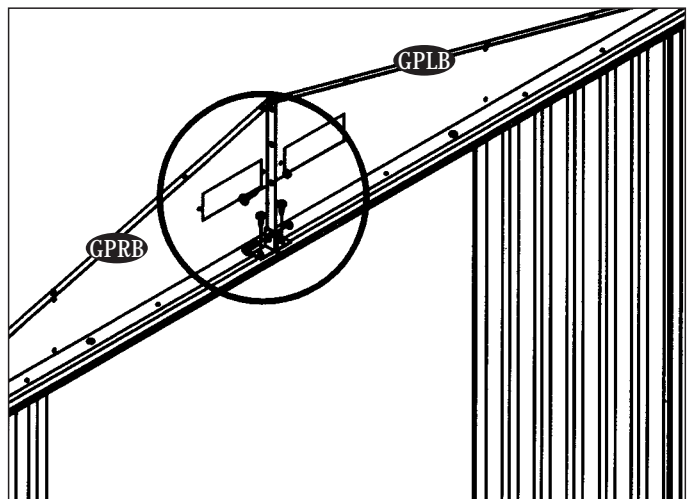

Fig.2



4. Place the Gable panel (GPLB) & (GPRB) on top of the Top angle (ABRB) & (ABLB). Insert the Gable Panel into the Top angle side (ASB). Align the holes with Top angle and secure with (S1) screws.

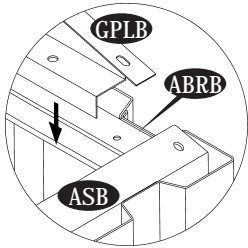

Fig.1

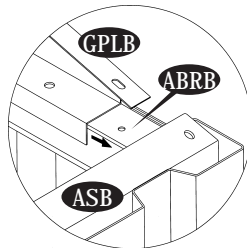

Fig.2

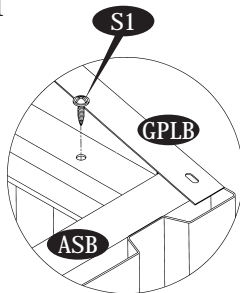
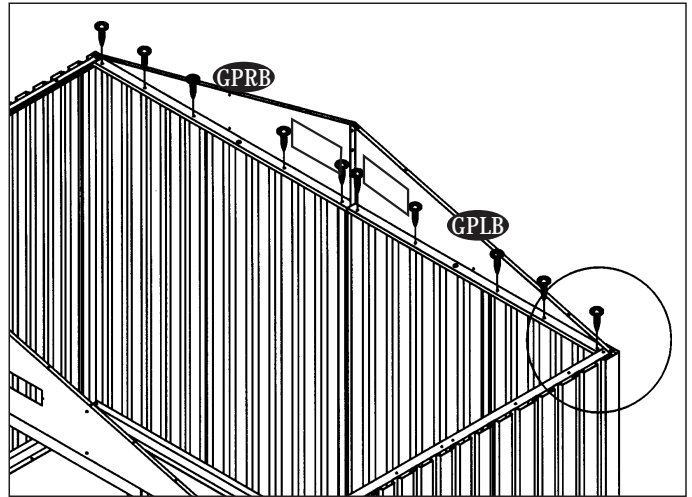
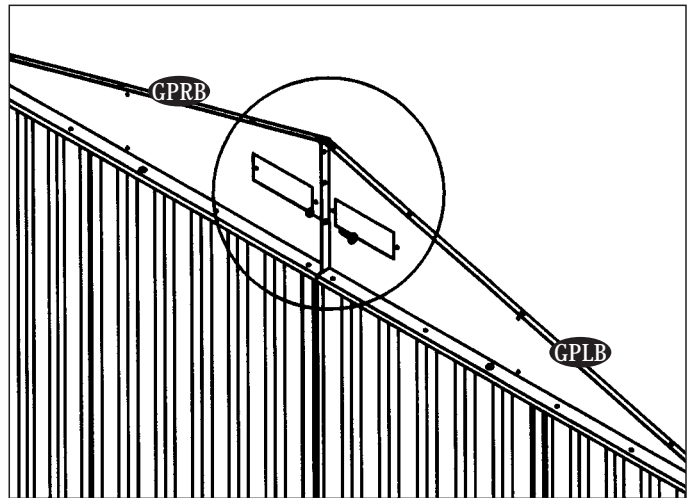
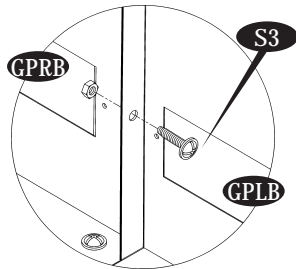

Fig.3



5. Assemble the Gable panel (GPLB) & (GPRB) together with (S3) bolt and nut. See fig.



6. Assemble the Roof structure (RSB) one end with roof support bracket (SB1B) & (SB2B) using (S3) bolt and nut. See fig. 1 & 2. Fix the other end also with roof support bracket (SB1B) & (SB2B).

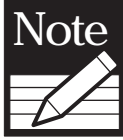

Make sure the taper side on (RSB) must be up side.

Taper side

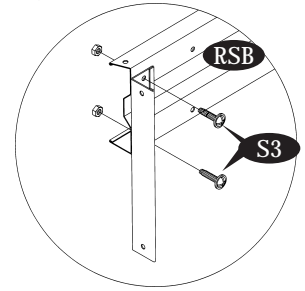
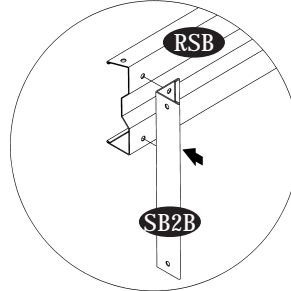
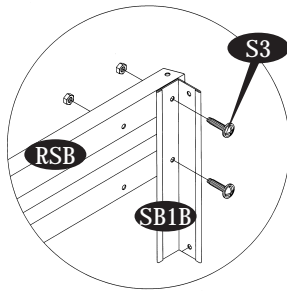
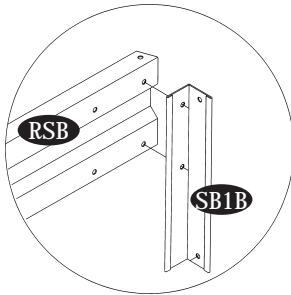
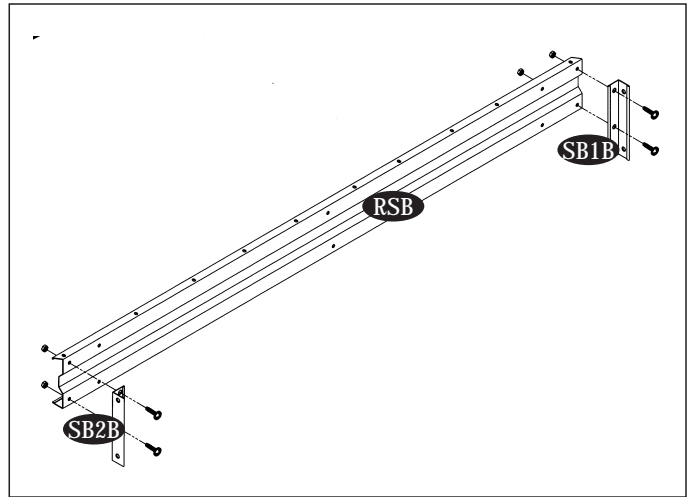
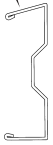

7. Fix assembled roof structure (RSB) into the Gable Panels (GPLB) & (GPRB). Align the holes between support bracket (SB1B) & (SB2B) and Gable Panels. Secure with bolt with plastic washer and nut (S3). See fig.

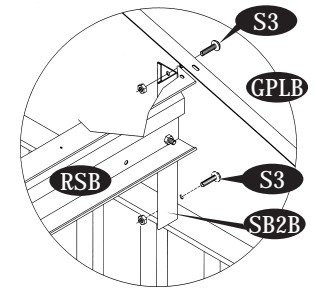
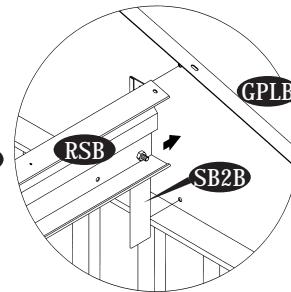
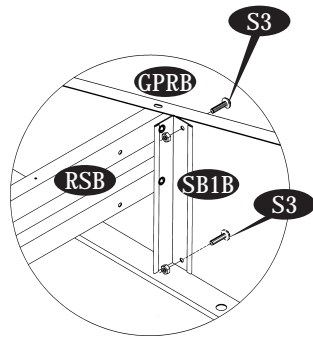
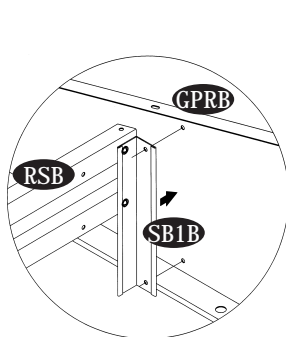
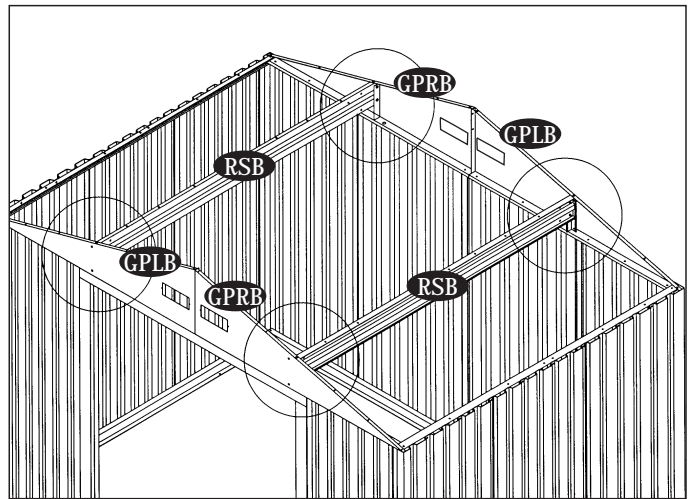

8. Assemble two roof structure (RSB) together with (S3) bolt and nut.

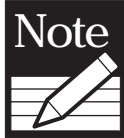

Make sure the taper side on (RSB) must be the same.

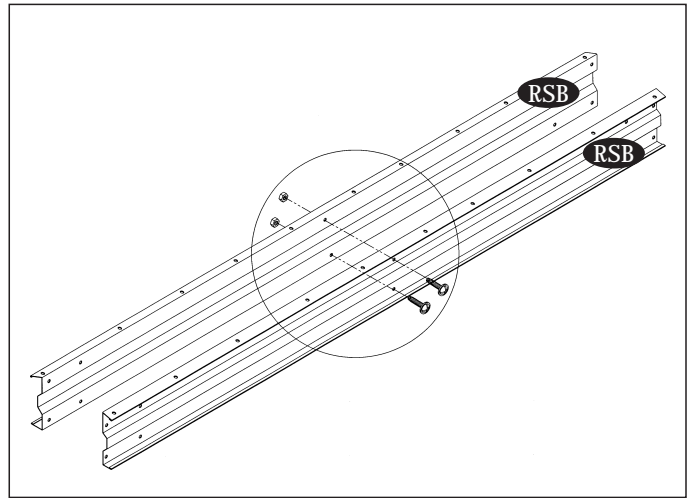
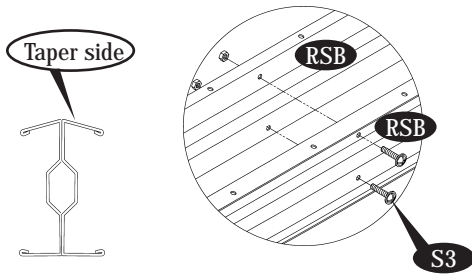

9. Insert the one end of the roof structure assembly to the Gable panel. The Gable panel should go in between the roof structure assembly. Secure with (S3) bolt and nut. Continue the same for the other end. See fig.1 & 2

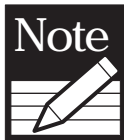

Make sure the taper side on (RSB) must be up.

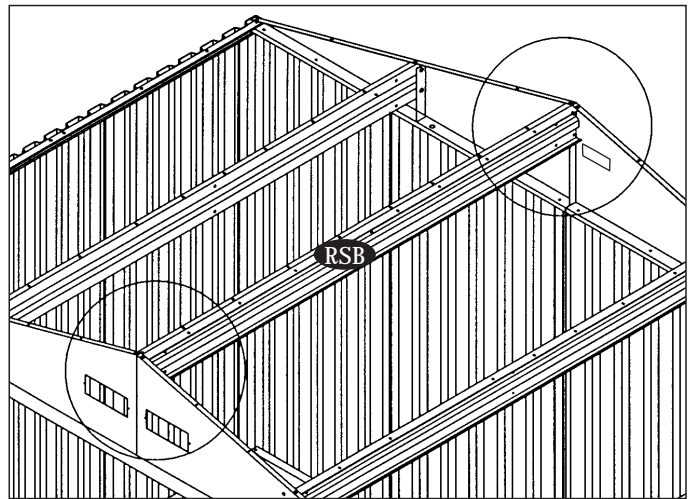
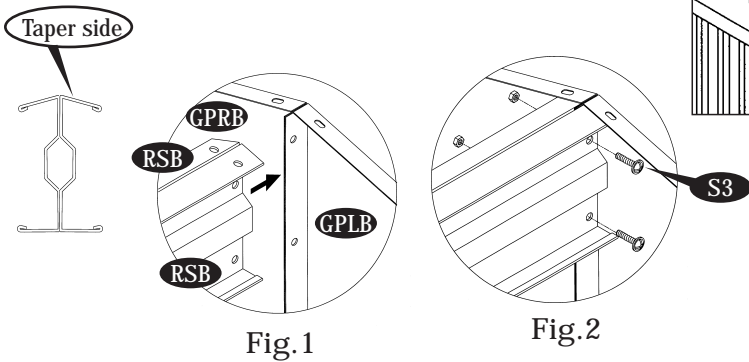

10. Place the roof panel (RP3B) on top of the Gable panel (GPRB). Line up the holes with Gable panel and secure with (S3) bolt and nut with washers.

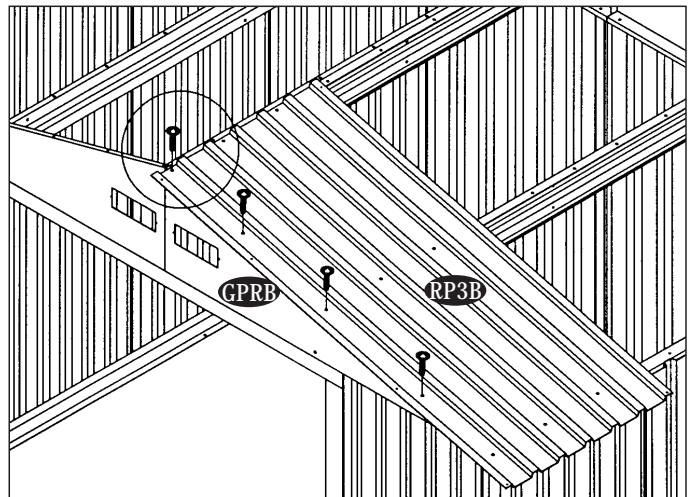
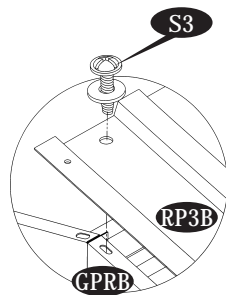

11. Line up the holes with Roof structure and Top angle side and secure with (S1) screws with washers.

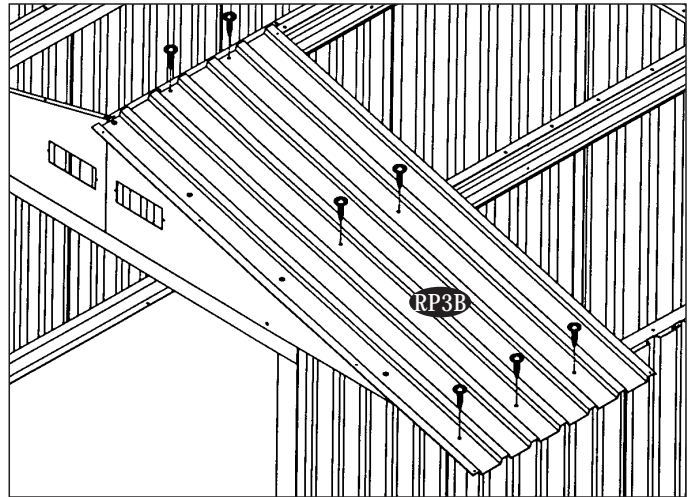

12. Place the Roof panel (RP2B) on the Roof structure and secure with (S1) screws with washers.

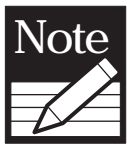

Make sure the overlapping position for Roof panel is as shown in blowup.

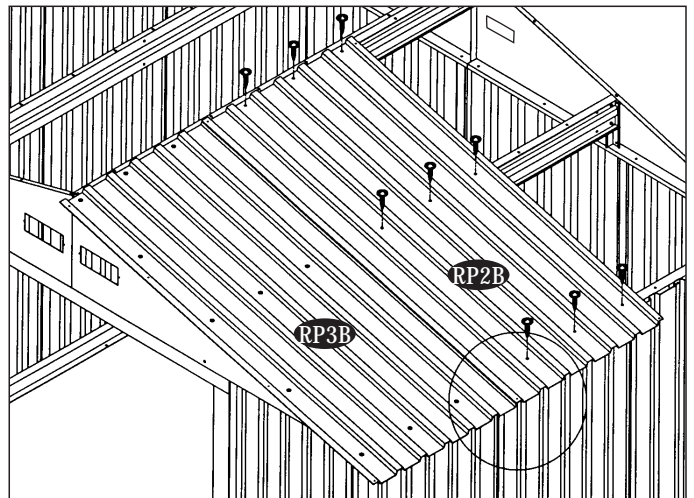
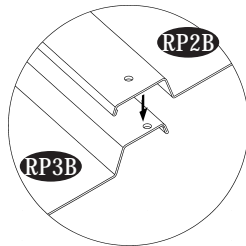

13. Place the Roof panel (RP1B) on the Roof structure and Gable panel. Secure with (S1) screws with washers to Roof structure. Use (S3) bolt and nut with washers for Gable panel.

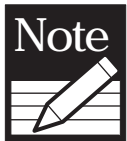

Make sure the overlapping position for Roof panel is as shown in blowup.

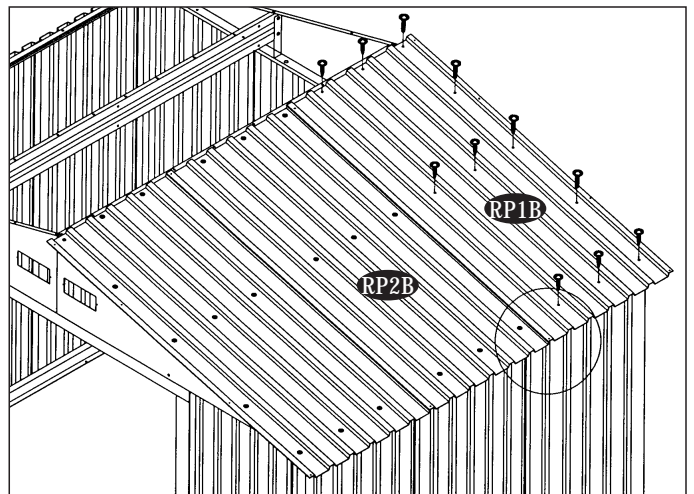
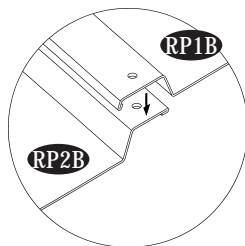

14. Place the Roof panel (RP3B) on top of Gable panel and Roof structure. Use (S3) bolt and nut with washers for Gable panel and use (S1) screws with washers to secure with Roof structure and Top angle side.

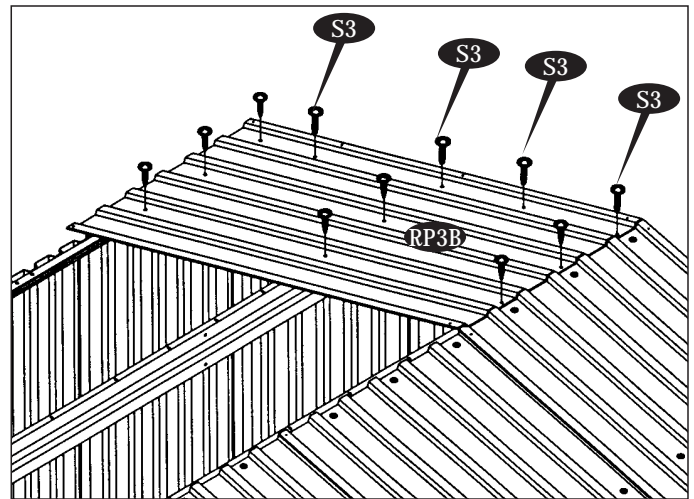

15. Place the Roof panel (RP2B) on the Roof structure and secure with (S1) screws with washers.

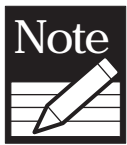

Make sure the overlapping position for Roof panel is as shown in blowup.

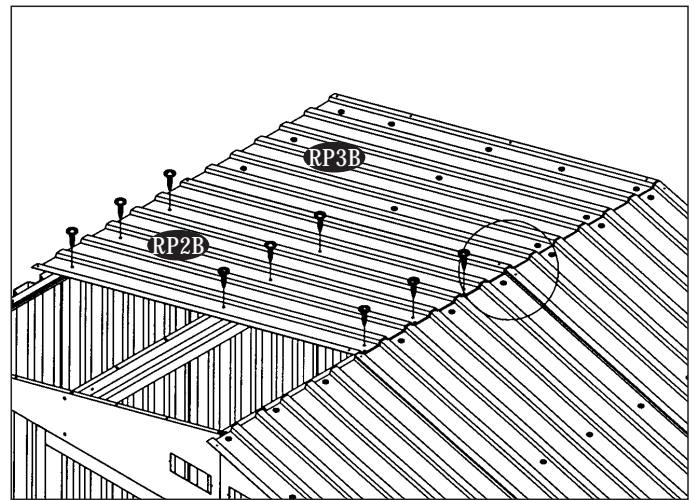
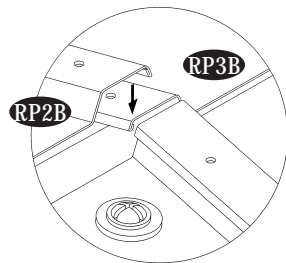

16. Place the Roof panel (RP1B) and secure with (S3) bolt and nut with washers to Gable panel and use (S1) screws with washers to the Roof structure & top angle side.

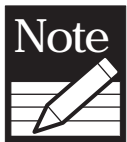

Make sure the overlapping position for Roof panel is as shown in blowup.

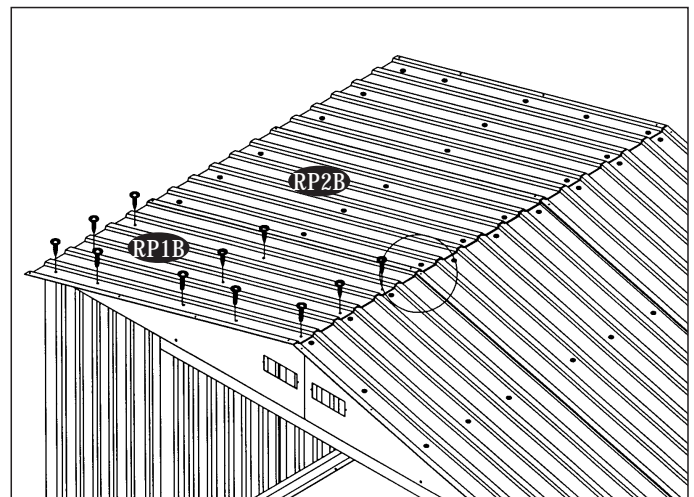
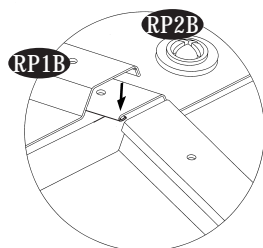

17. Put provided weather stripping tape between roof panels (Left & Right) before fixing all roof flashing.

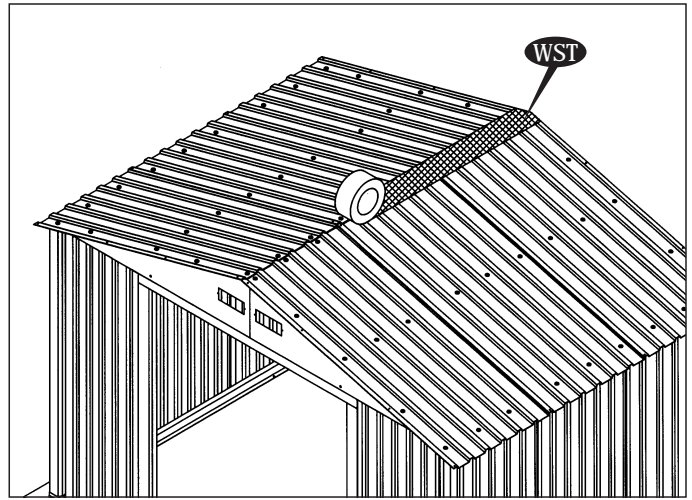

18. Assemble the roof flashing (RF1B) & (RF2B) with Roof panel. Secure with (S1) screws with washers.

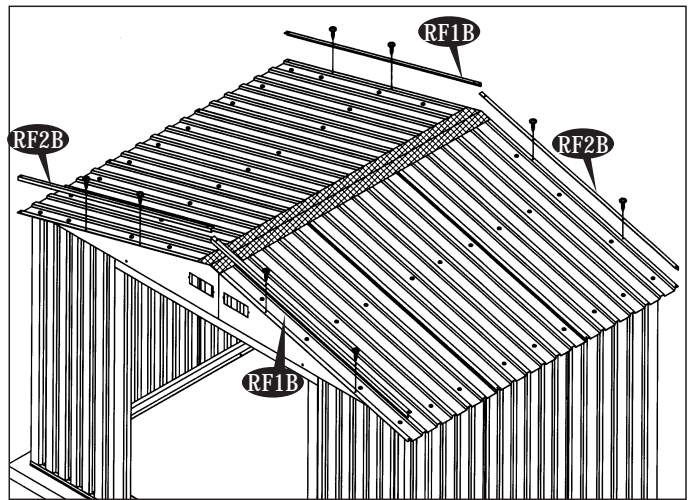

19. Assemble the roof flashing (RF3B) & (RF4B) with Roof panel. Secure with (S1) screws with washers.

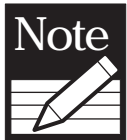

Make sure the overlapping position for Roof flashing is as shown in blowup.

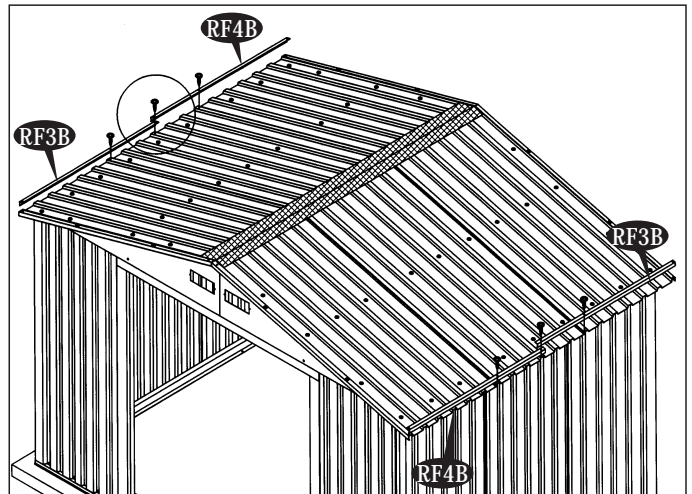
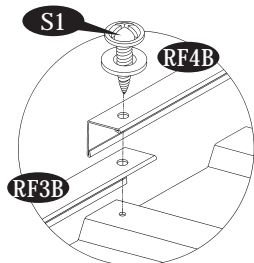

20. Assemble together the Roof flashing center (RFCB) with (S1) screws with washers. See the blow up.

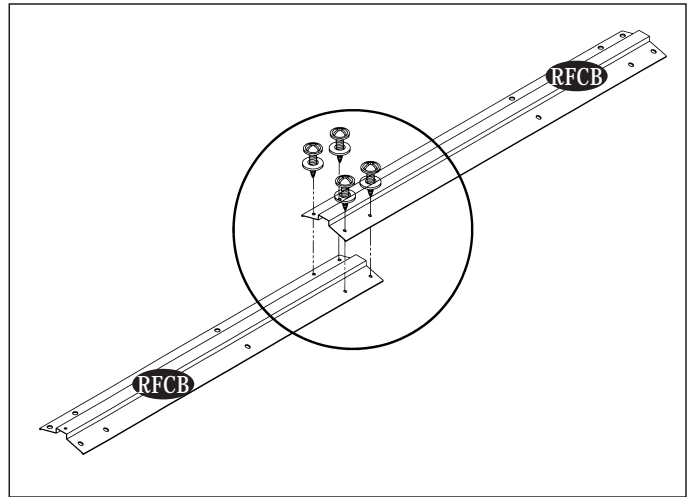
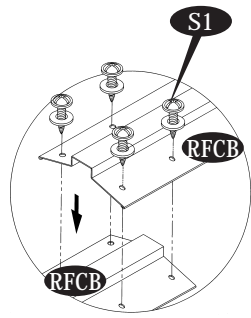

21. Place the assembled roof flashing center on Top of Roof panels. Line up the holes and secure with (S1) screws with washers.

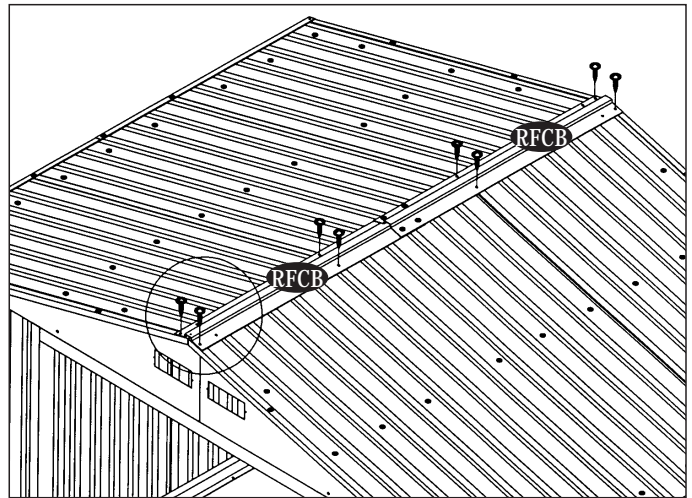
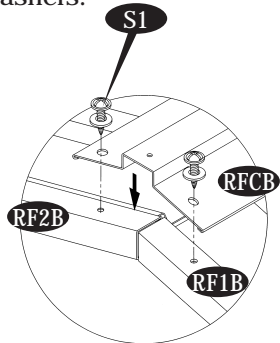

22. Slide the flashing end cap to the front & back top of the roof and secure with (S1) screws with washers. See fig. 1 & 2

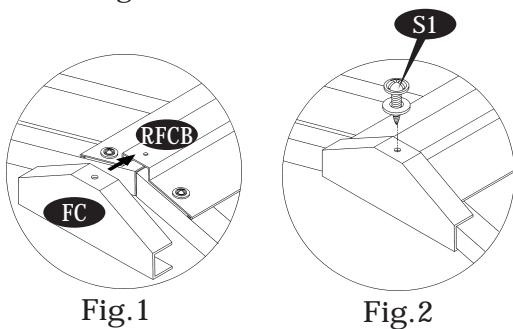
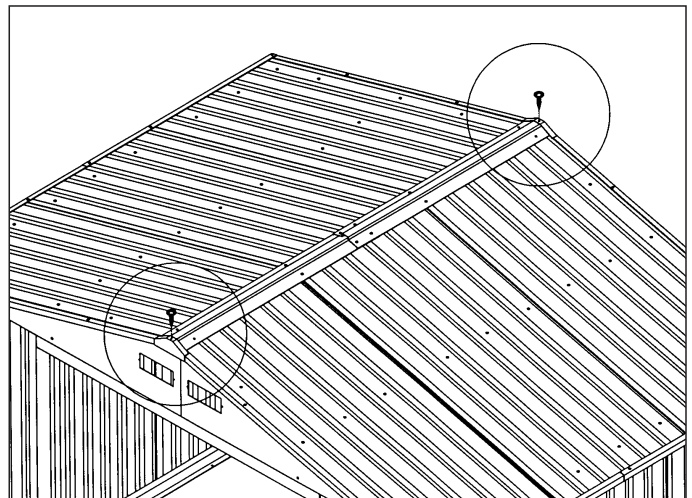
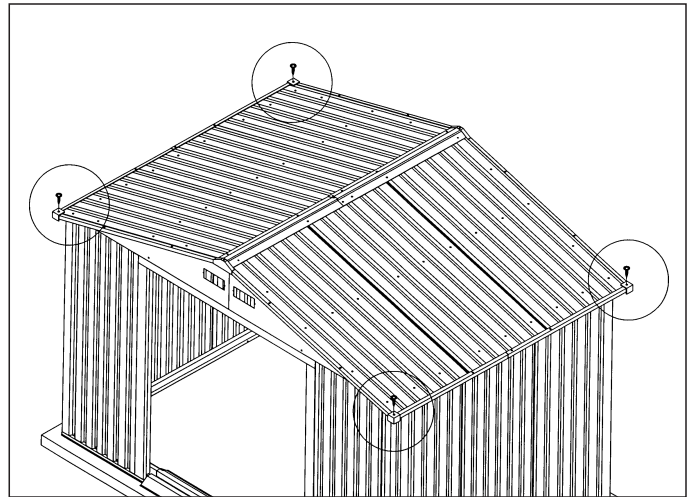
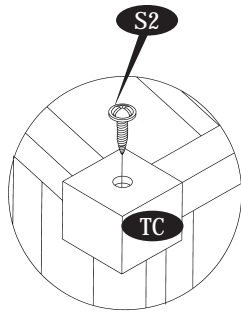

Fig.1

Fig.2



23. Place the Top corner (TC) on the Roof flashing joints and secure with (S2) screws with washers.



24. Insert the ventilation cover (VC) into the Front Gable panel and secure with (S1) screws.

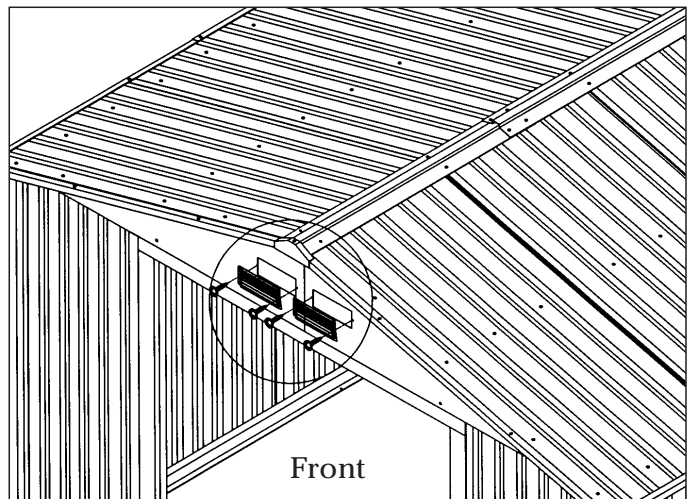
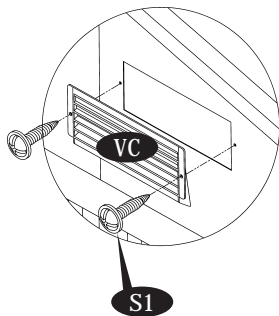

25. Insert the ventilation cover (VC) into the back Gable panel and secure with (S1) screws.

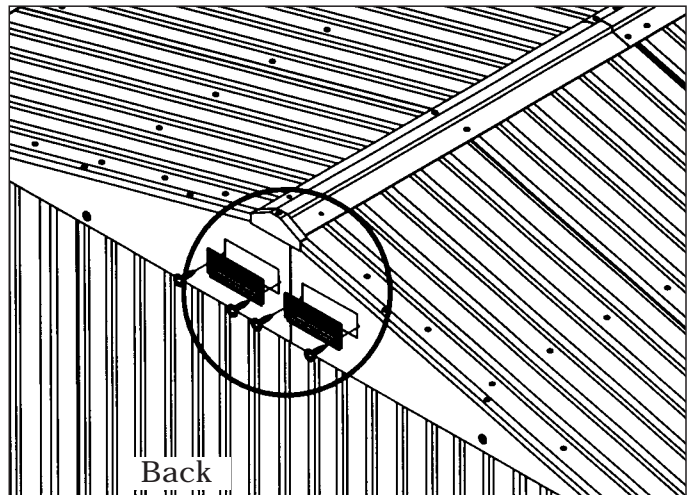
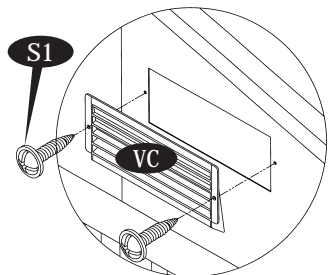

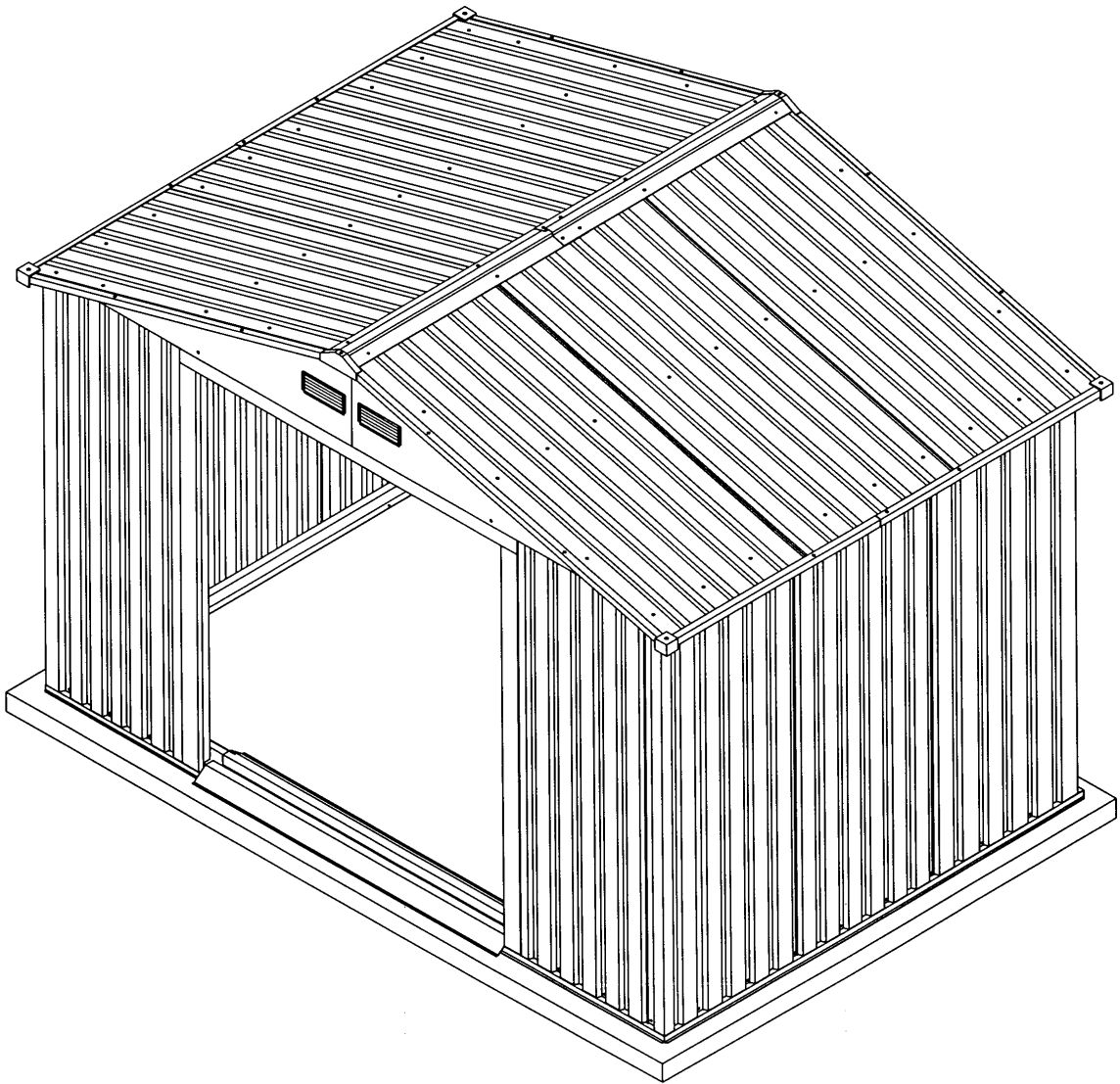

D. Door

Parts Needed:

- | | |
|---|--------|
| (1) Door panel left | (DPLB) |
| (1) Door panel right | (DPRB) |
| (4) Door panel strip cross | (DSCB) |
| (2) Door panel strips side left and right | (DSS) |
| (1) Door panel strip top left | (TSLB) |
| (1) Door panel strip top right | (TSRB) |
| (1) Door panel strip bottom left | (BSLB) |
| (1) Door panel strip bottom right | (BSRB) |
| (2) Door handle | (DH) |
| (4) Bottom Slider | (BS) |
| (22) Plastic washer | (PW) |
| (10) Sheet metal screw | (S1) |
| (24) Machine screw | (S3) |

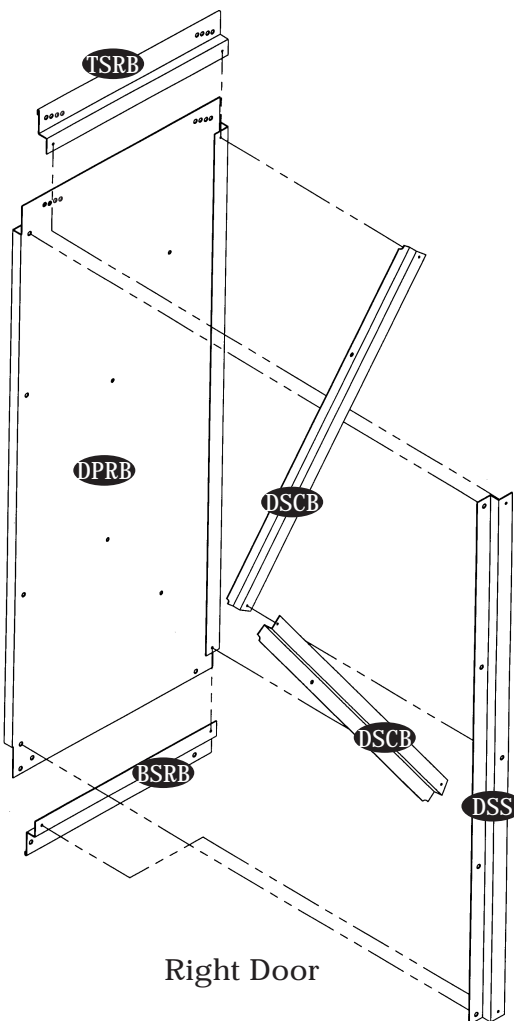
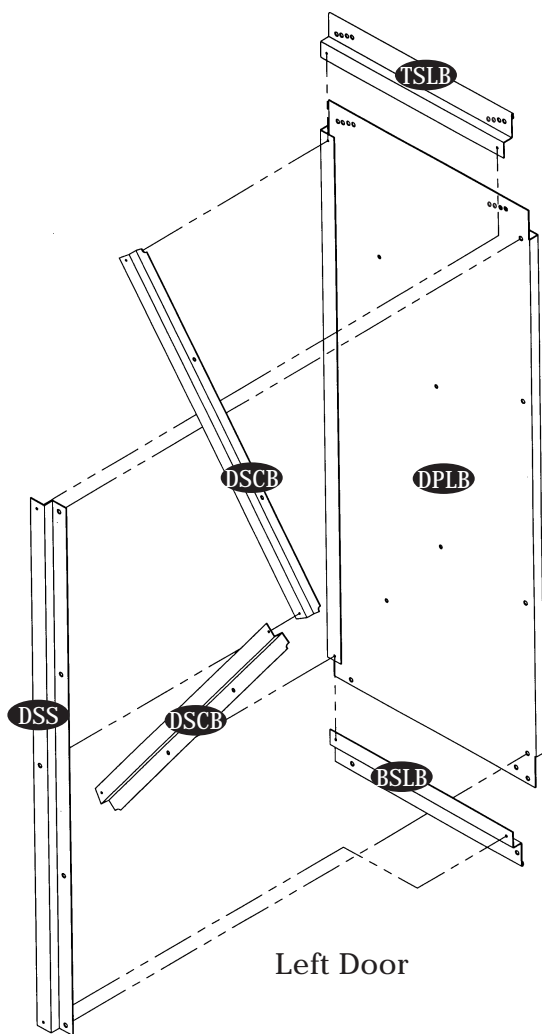

Right Door Assembly

1. Assemble the door panel strip side (DSS) to the door panel right (DPRB) from inside. Use (S3) bolt and nut with washers.

Note *Remove the Polyethylene Film before assembling.*

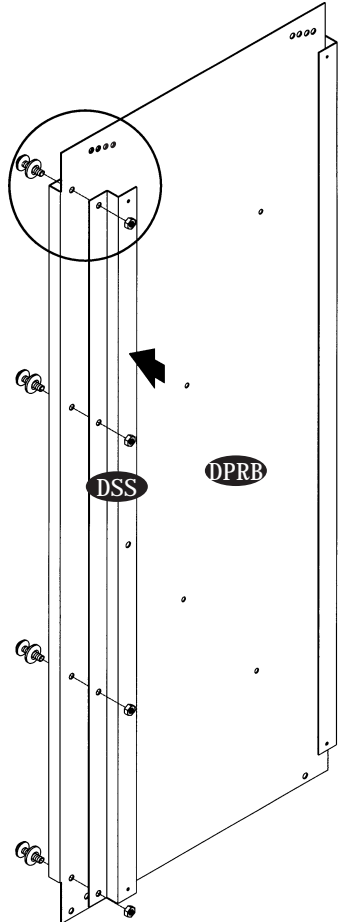
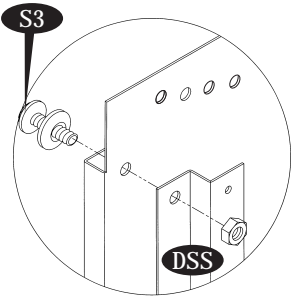

2. Assemble the door panel strip cross (DSCB) with door panel from inside. The strip one edge should go inside the (DSS) and other edge inside the door panel. Use (S3) bolt and nut with washers.

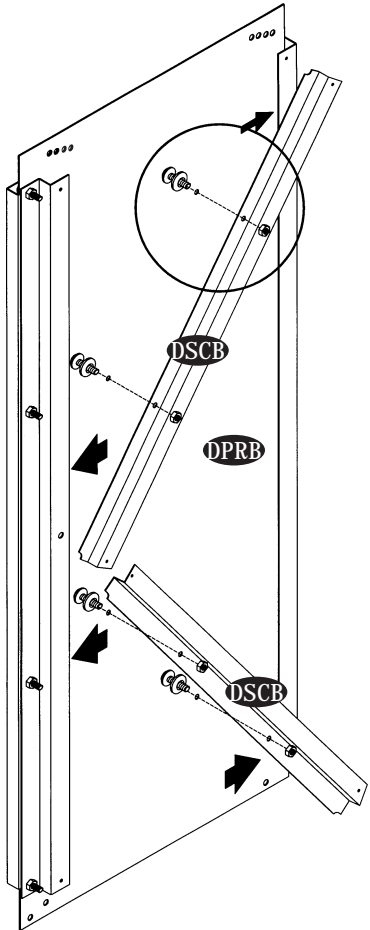
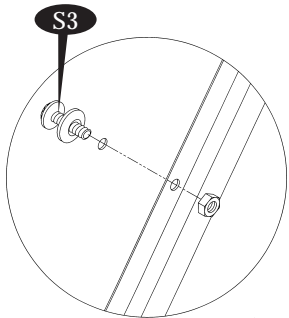

3. Secure the door panel strip cross (DSCB) to the door panel strip side (DSS) with (S1) screws. See blow up details.

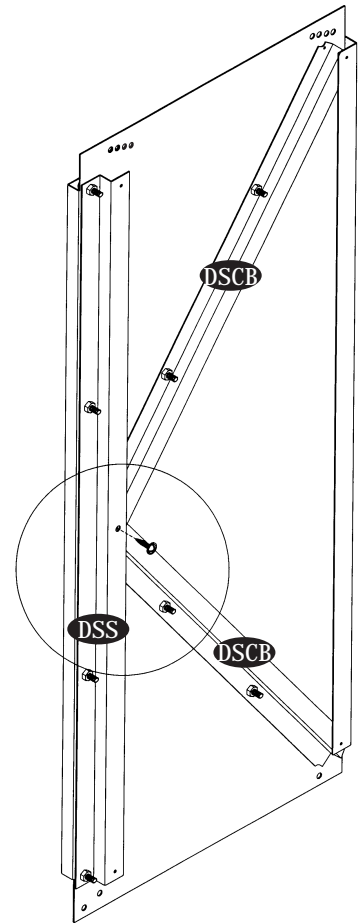
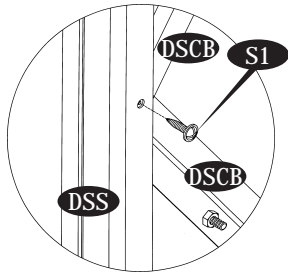

4. Assemble the door panel strip (TSRB) with door panel. Make sure the door panel top edge to be inserted into the (TSRB). See fig.1.
 Secure the (TSRB) to the (DSS) with (S1) screws. See fig. 2.
 Secure the other end through the door panel to the (DSCB) with (S1) screws. See fig. 3.

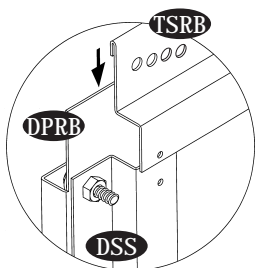

Fig.1

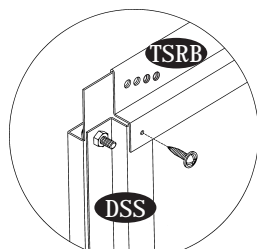

Fig.2

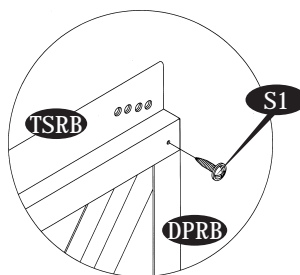
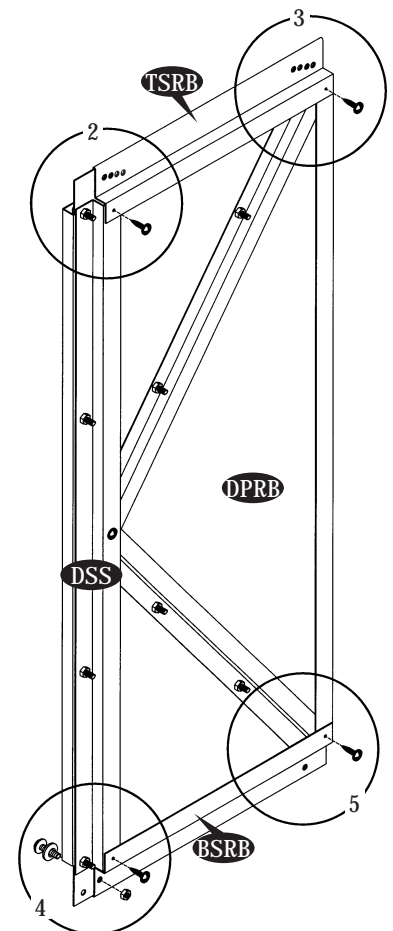

Fig.3



4a. Assemble the door panel strip (BSRB) with door panel. Make sure the bottom edge of the door panel to be inserted into the (BSRB). Secure with (S1) screws to the (DSS). See fig. 5. Use (S3) bolt and nut with washer with door panel. See fig. 4.

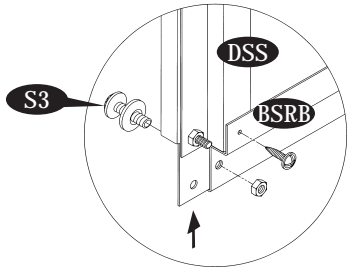

Fig.4

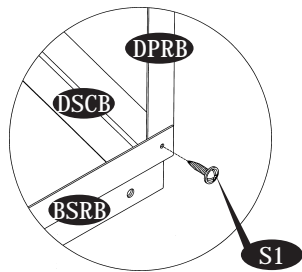
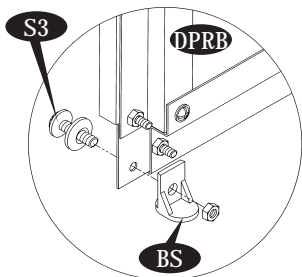
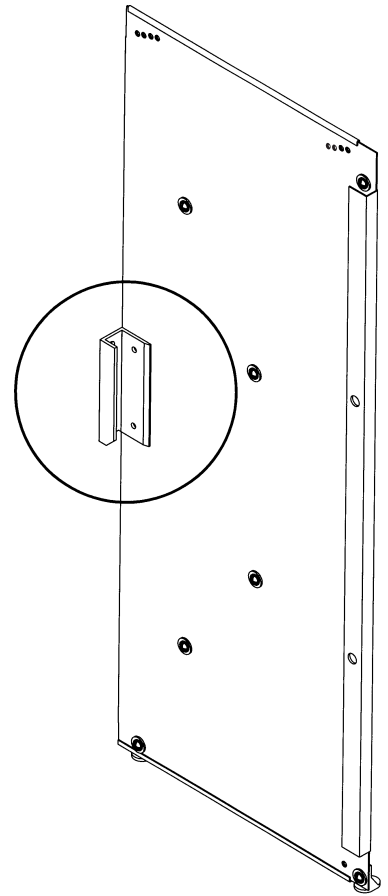
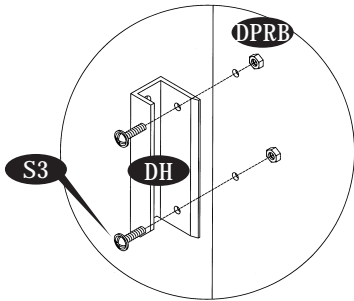

Fig.5

5. Assemble the bottom slider (BS) to the door panel bottom side at both edge with (S3) bolt and nut with washer.



6. Fix the door handle (DH) with door panel from front side with (S3) bolt and nut.



Left Door Assembly

7. Assemble the door panel strip side (DSS) to the door panel left (DPLB) from inside. Use (S3) bolt and nut with washers.

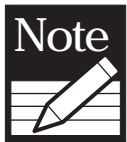

Remove the Polyethylene Film before assembling.

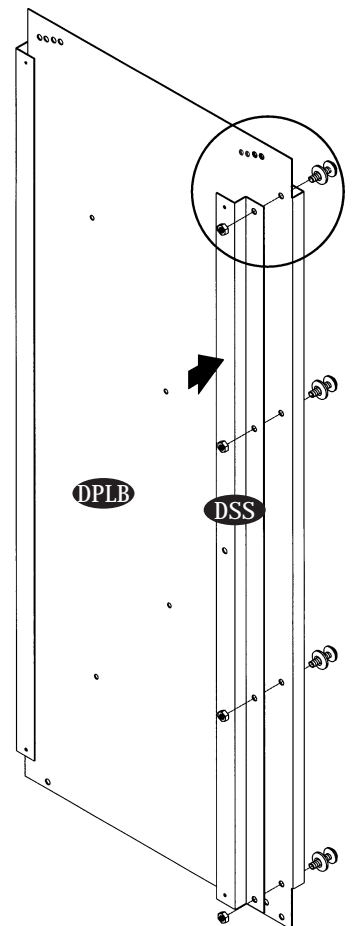
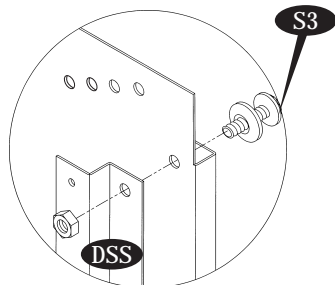

8. Assemble the door panel strip cross (DSCB) with door panel from inside. The strip one edge should go inside the (DSS) and other edge inside the door panel. Use (S3) bolt and nut with washers.

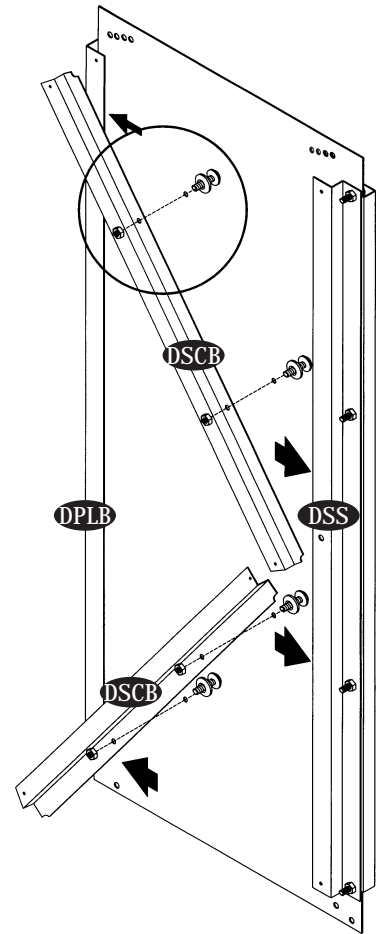
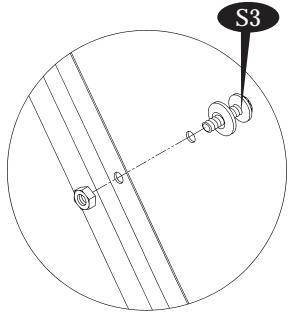

9. Secure the door panel strip cross (DSCB) to the door panel strip side (DSS) with (S1) screws. See blow up details.

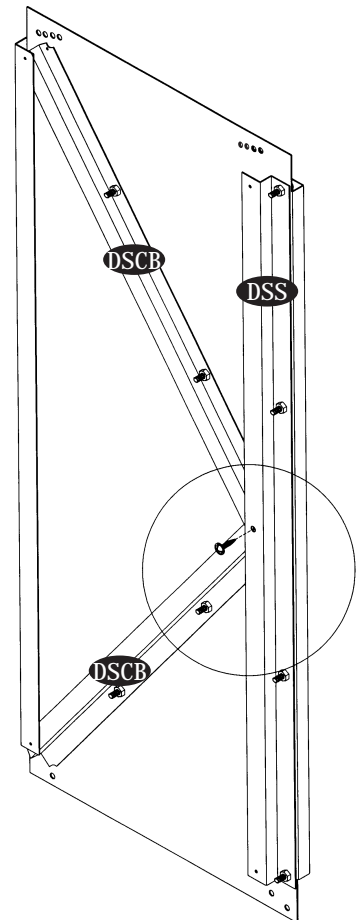
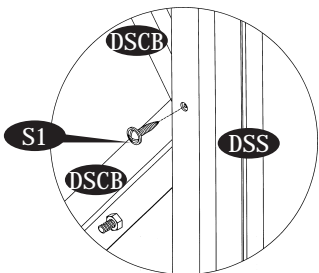

10. Assemble the door panel strip (TSLB) with door panel. Make sure the door panel top edge to be inserted into the (TSLB). See fig.1.
 Secure the (TSLB) to the (DSS) with (S1) screws. See fig. 2.
 Secure the other end through the door panel to the (DSCB) with (S1) screws. See fig. 3.

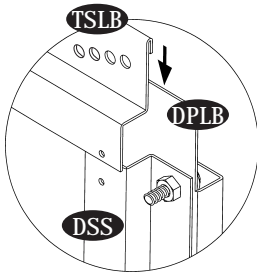

Fig.1

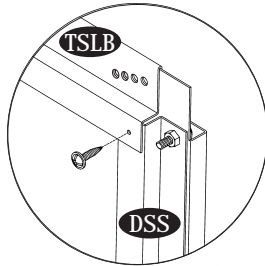

Fig.2

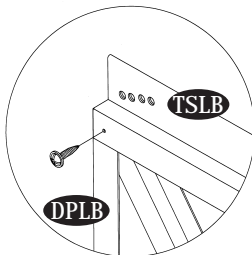
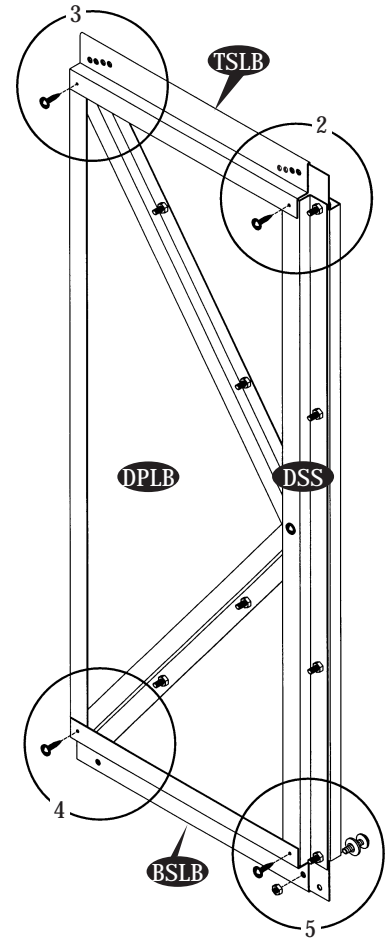

Fig.3



11a. Assemble the door panel strip (BSLB) with door panel. Make sure the bottom edge of the door panel to be inserted into the (BSLB). Secure with (S1) screws to the (DSS). See fig. 4. Use (S3) bolt and nut with washer with door panel. See fig. 5.

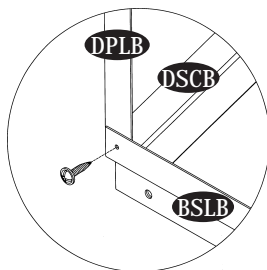

Fig.4

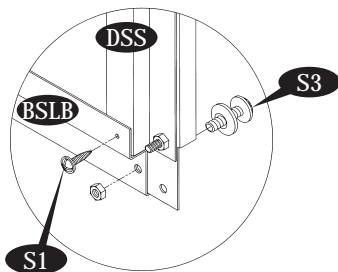
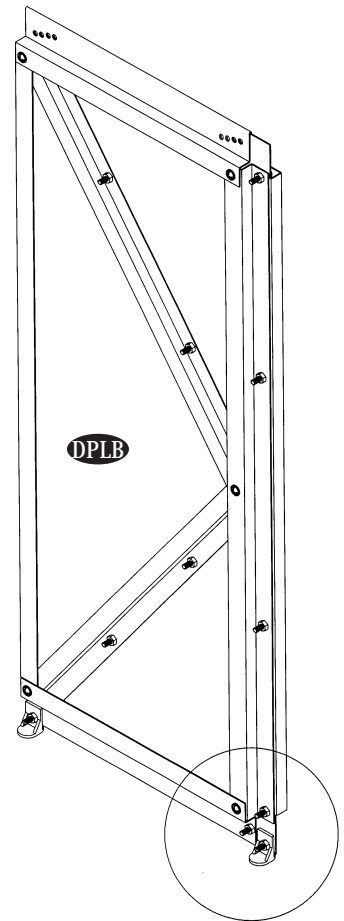
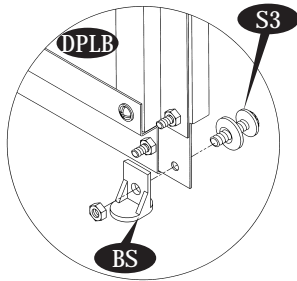
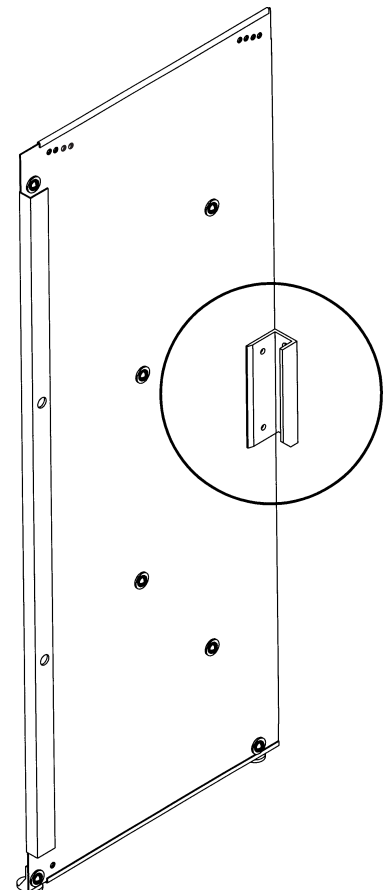
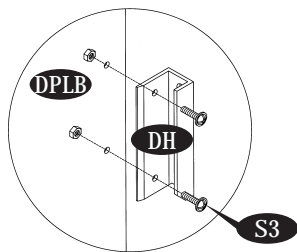

Fig.5

12. Assemble the bottom slider (BS) to the door panel bottom side at both edge with (S3) bolt and nut with washers.



13. Fix the door handle (DH) with door panel from front side with (S3) bolt and nut.



14. Slide the door panel assembly into the base bar front (BBF). Make sure the bottom slider (BS) should slide inside the base bar front. See fig.1. Fix the door panel top to the top slider (TS) with (S1) screws. See fig. 2 & 3.

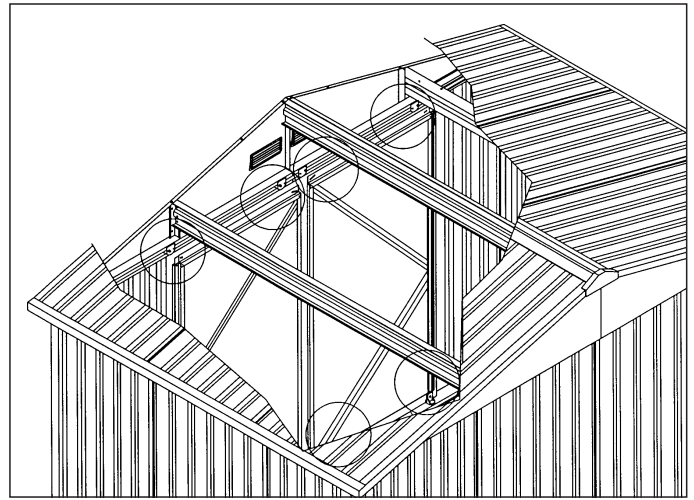
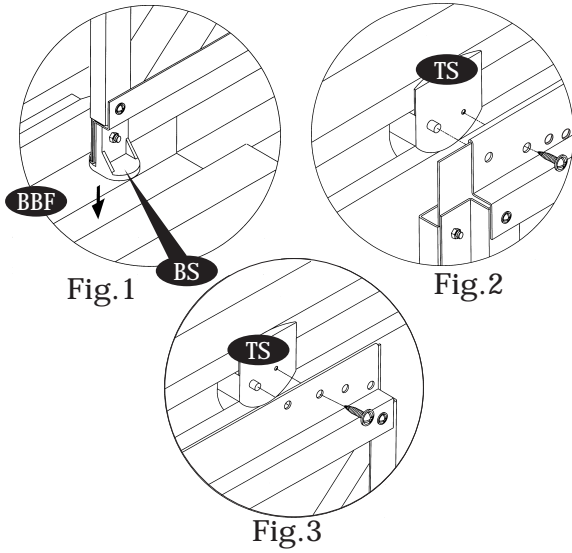

14a. To get proper alignment of the door realign the holes with door panel. See fig.

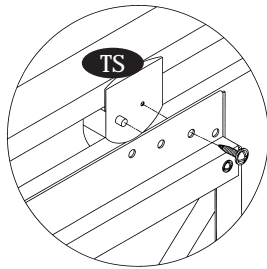
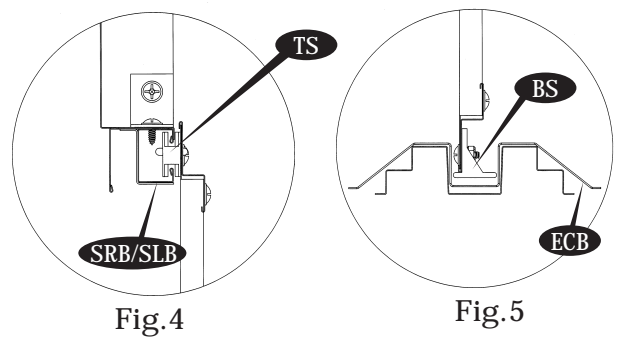

IMPORTANT

15. Fix the plastic screw cover (PC) to the screws and bolts edge from inside to prevent injury.

