

BillyOh Keeper Overlap  
Apex Range<sup>®</sup>  
Windowed  
Technical Details



For Queries and Help  
please call Product  
Support:  
01636 858377

**PROPRIETARY AND CONFIDENTIALITY**

All the information contained within this document including all technical data, dimensions, shape/form and branding (inc. Trademarks, logos, etc.) Is the sole property of Kybotech Limited. The reproduction and/or disclosure to any third party of any information contained within this document is strictly prohibited. Breaches of the copyright will be dealt with on the highest level of severity with immediate legal proceedings.

# 6ft Gable Windowed Overlap Shed

## Double Door Range

Front elevation: width 2.009m/6' 7"

## Sizes available

available in standard 7mm cladding types

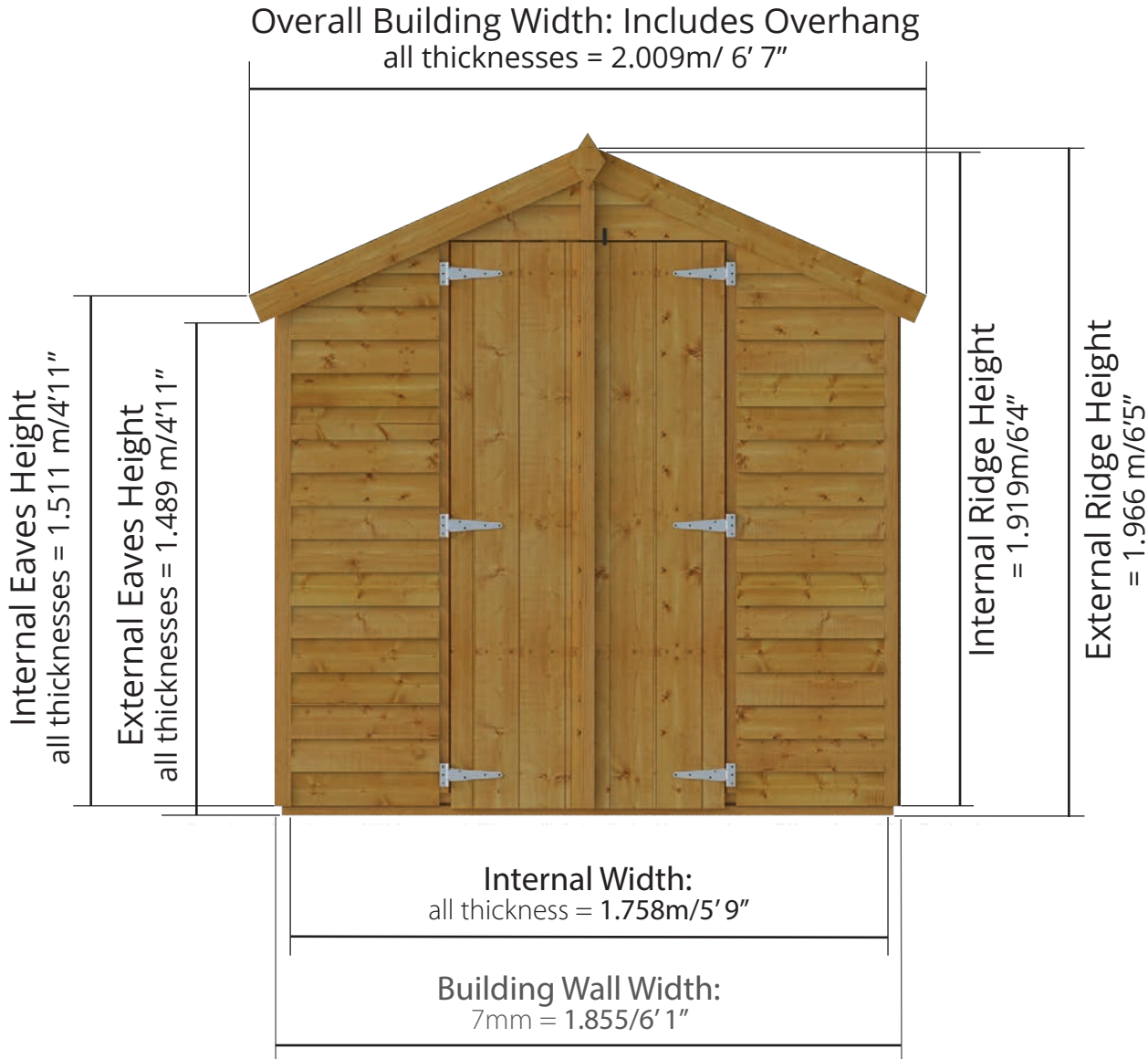

Windowed OL Shed  
D12ft x W6ft  
(Including Overhang)



Windowed OL Shed  
D16ft x W6ft  
(Including Overhang)



Windowed OL Shed  
D8ft x W6ft  
(Including Overhang)



Windowed OL Shed  
D10ft x W6ft  
(Including Overhang)



Windowed OL Shed  
D4ft x W6ft  
(Including Overhang)



D4.754m x W2.009m / D6' 7" x W16' 7"

# Windowed Overlap Apex Shed:

## Side elevation

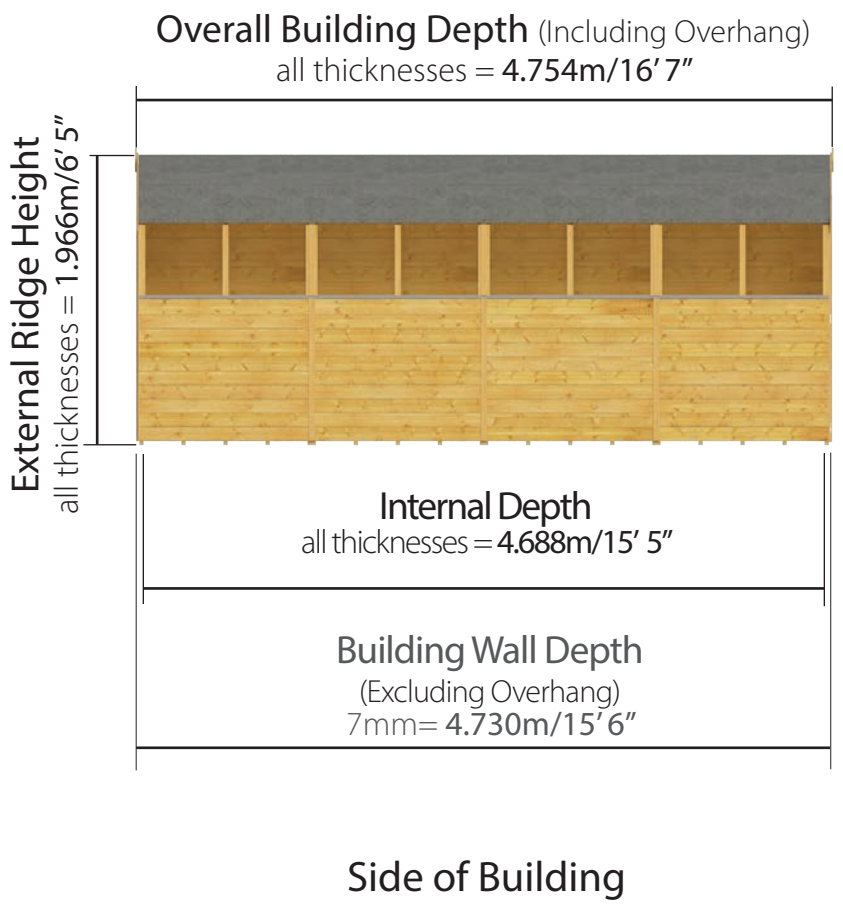

## Floor Plan

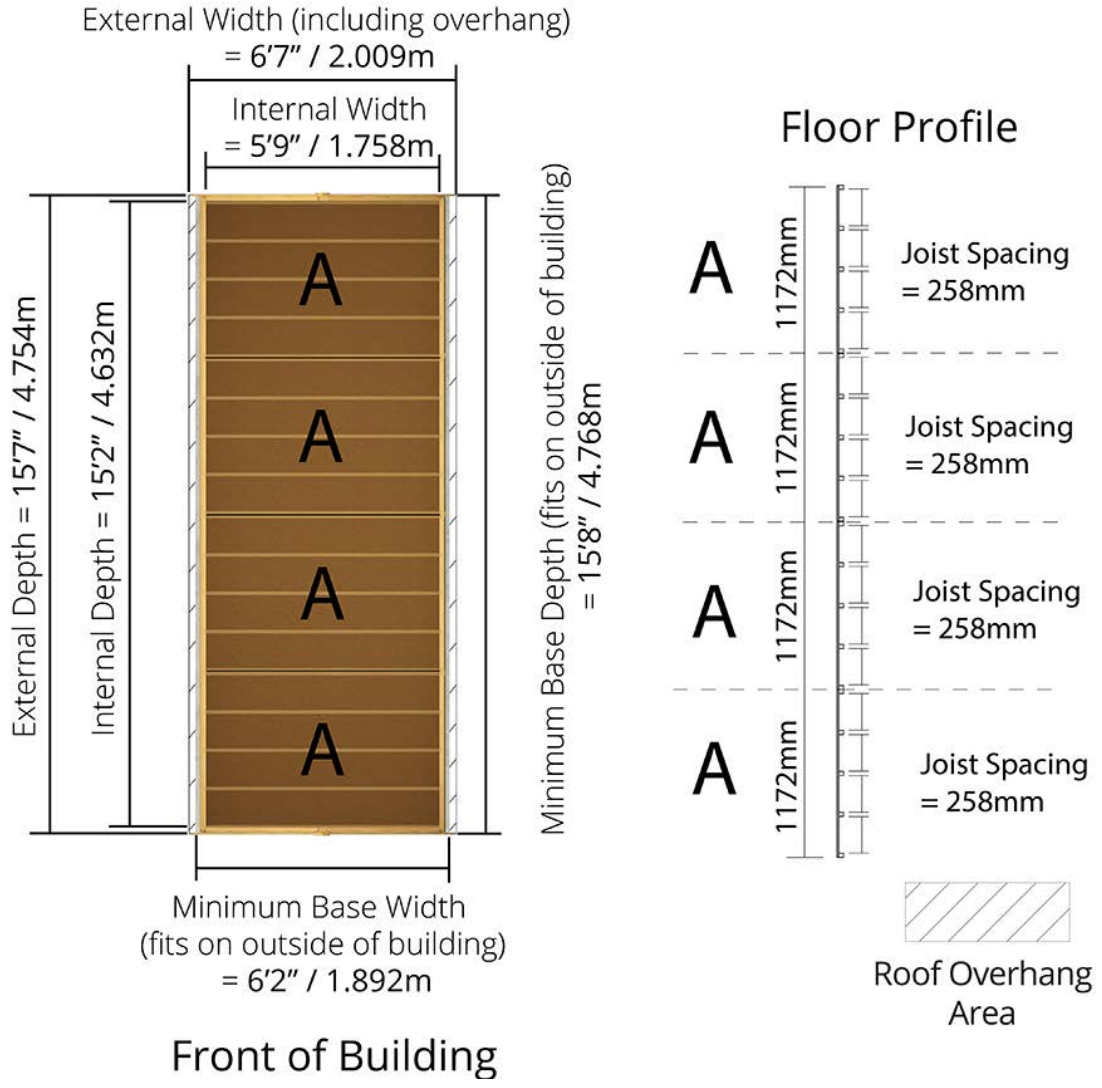

Please note: your base must be perfectly level and drainage is required to allow water to run off the surface. There must also be at least 2m clearance on each side to allow annual treatment to be applied.

# D4.754m x W2.009m / D6' 7" x W11' 9"

## Windowed Overlap Apex Shed:

### Side elevation

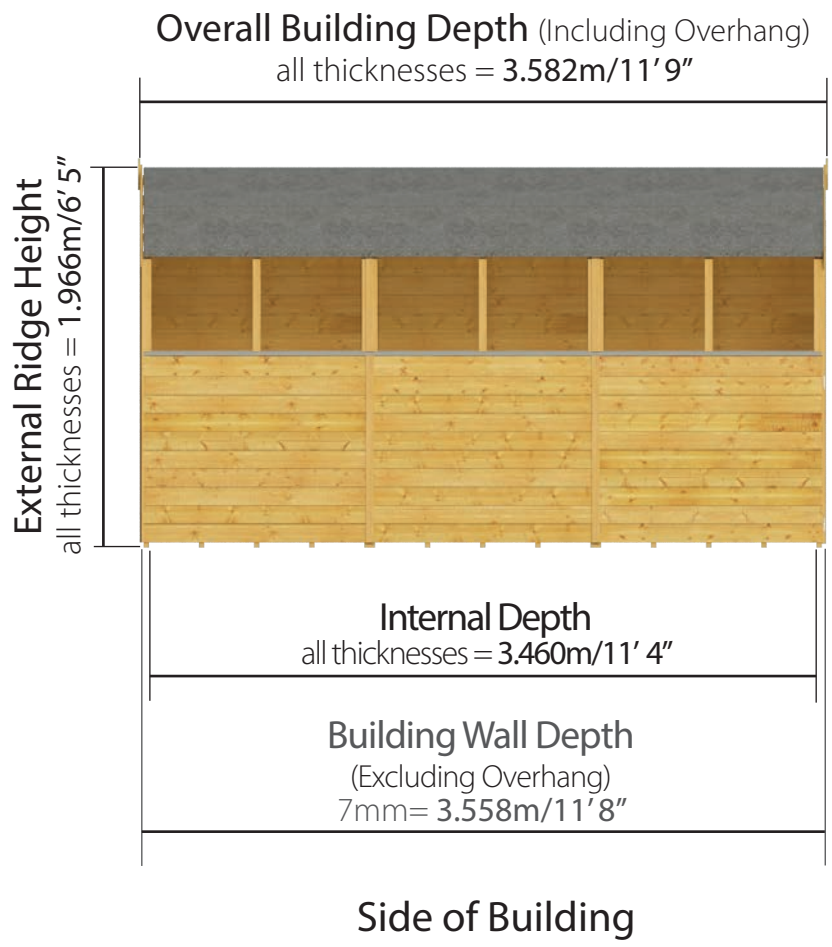

### Floor Plan

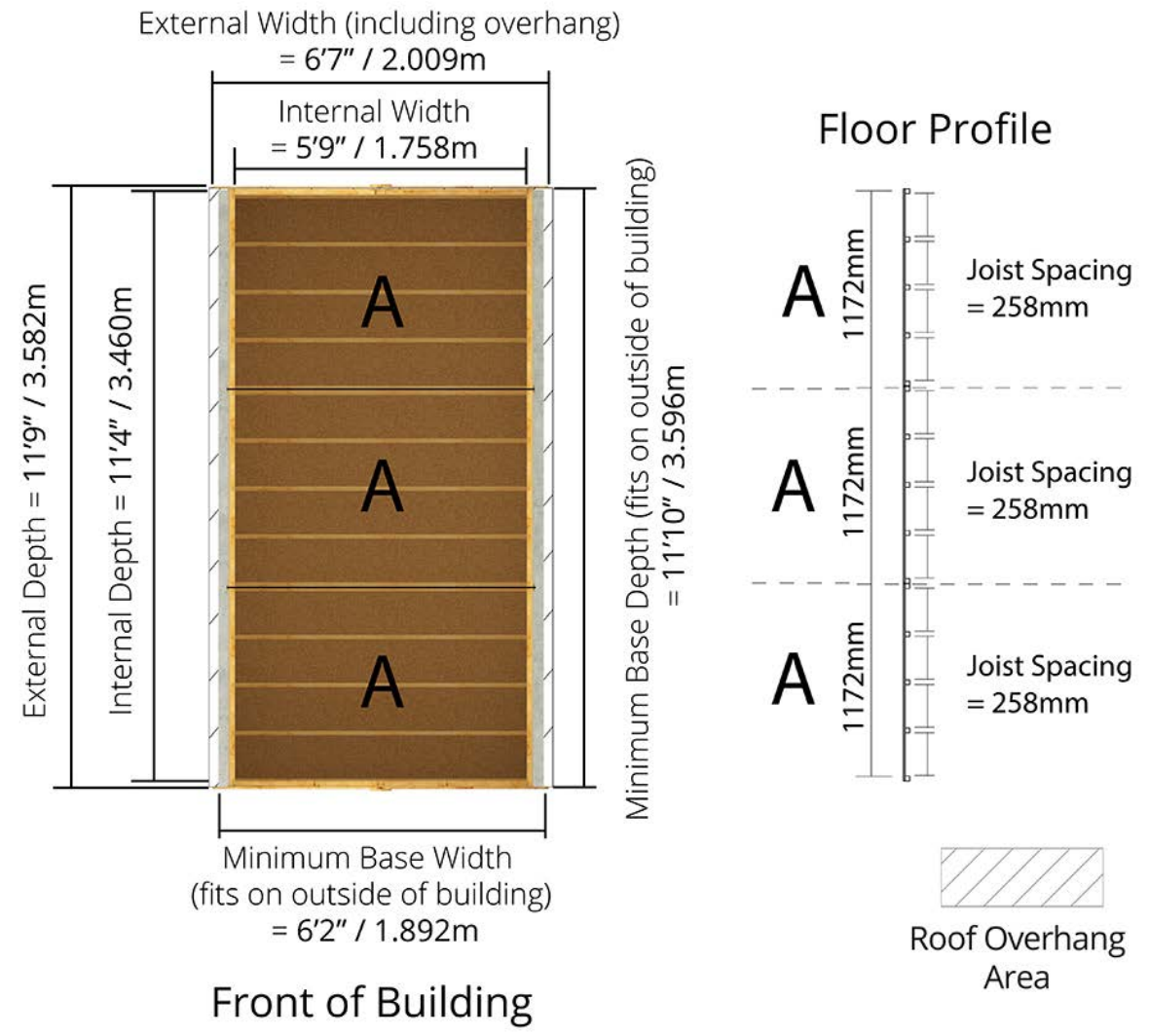

Please note: your base must be perfectly level and drainage is required to allow water to run off the surface. There must also be at least 2m clearance on each side to allow annual treatment to be applied.

D2.996m x W2.009m / D6' 7" x W9' 10"

# Windowed Overlap Apex Shed:

## Side elevation

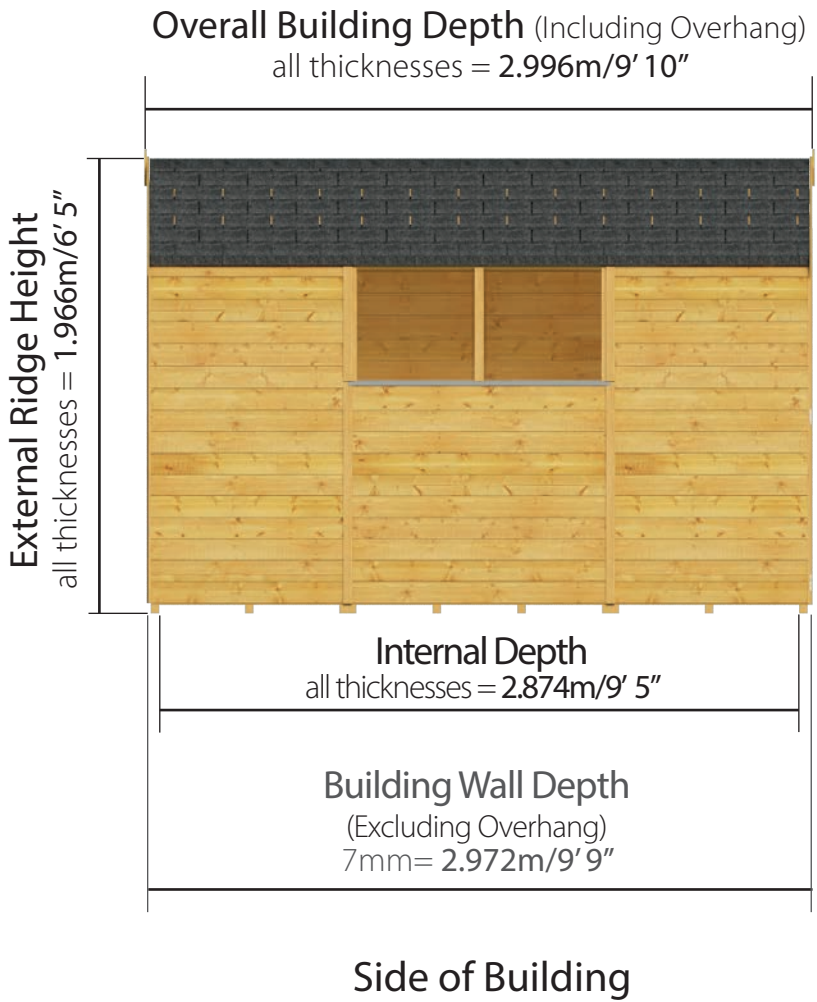

## Floor Plan

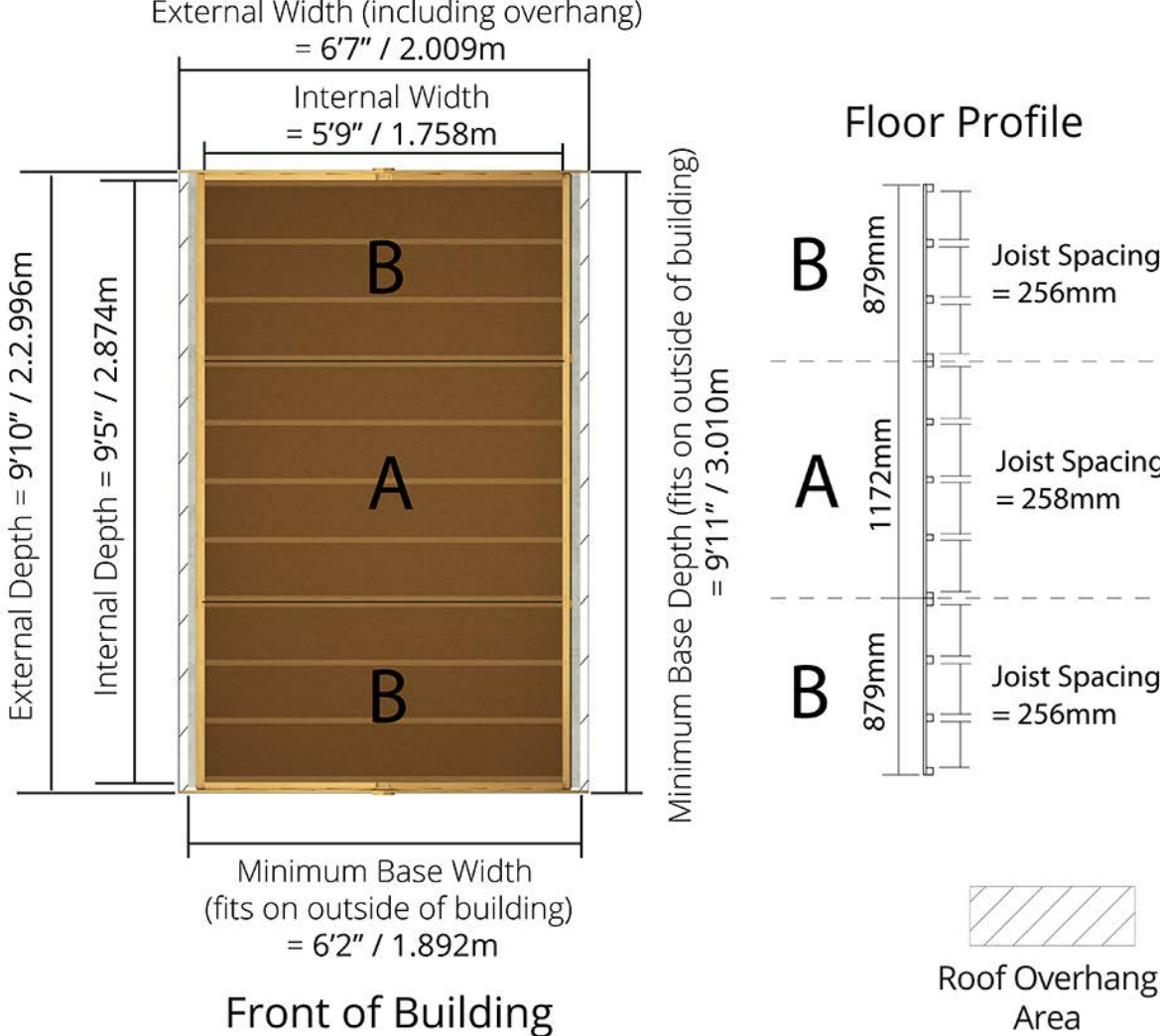

Please note: your base must be perfectly level and drainage is required to allow water to run off the surface. There must also be at least 2m clearance on each side to allow annual treatment to be applied.

# D2.410m x W2.009m / D6' 7" x W7' 11"

## Windowed Overlap Apex Shed:

### Side elevation

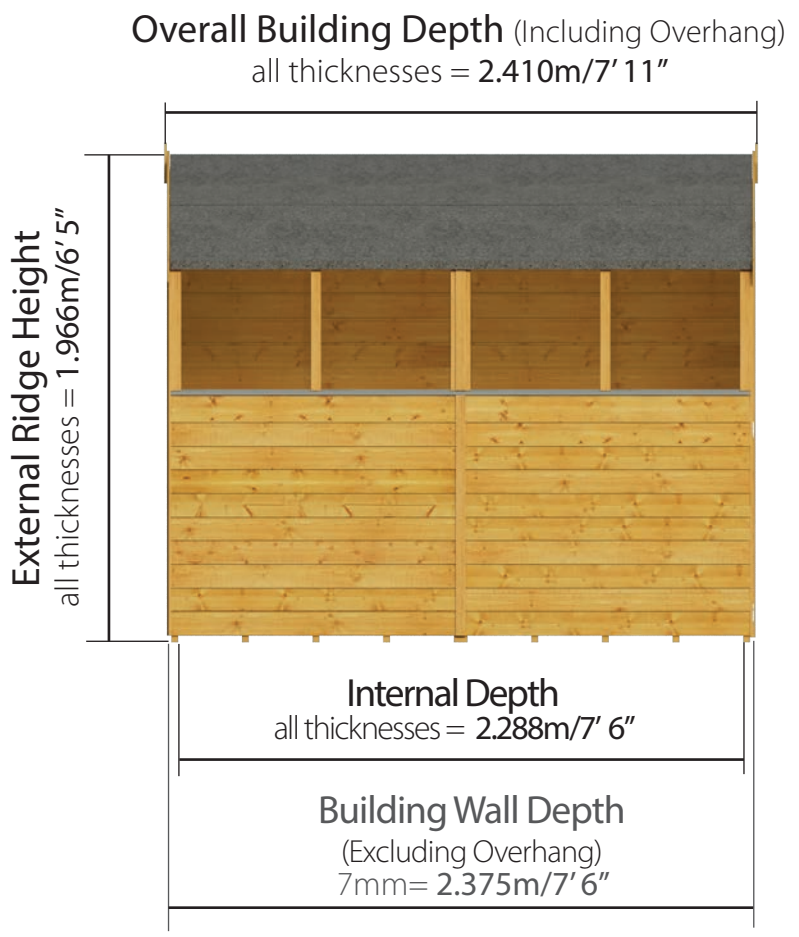

Side of Building

### Floor Plan

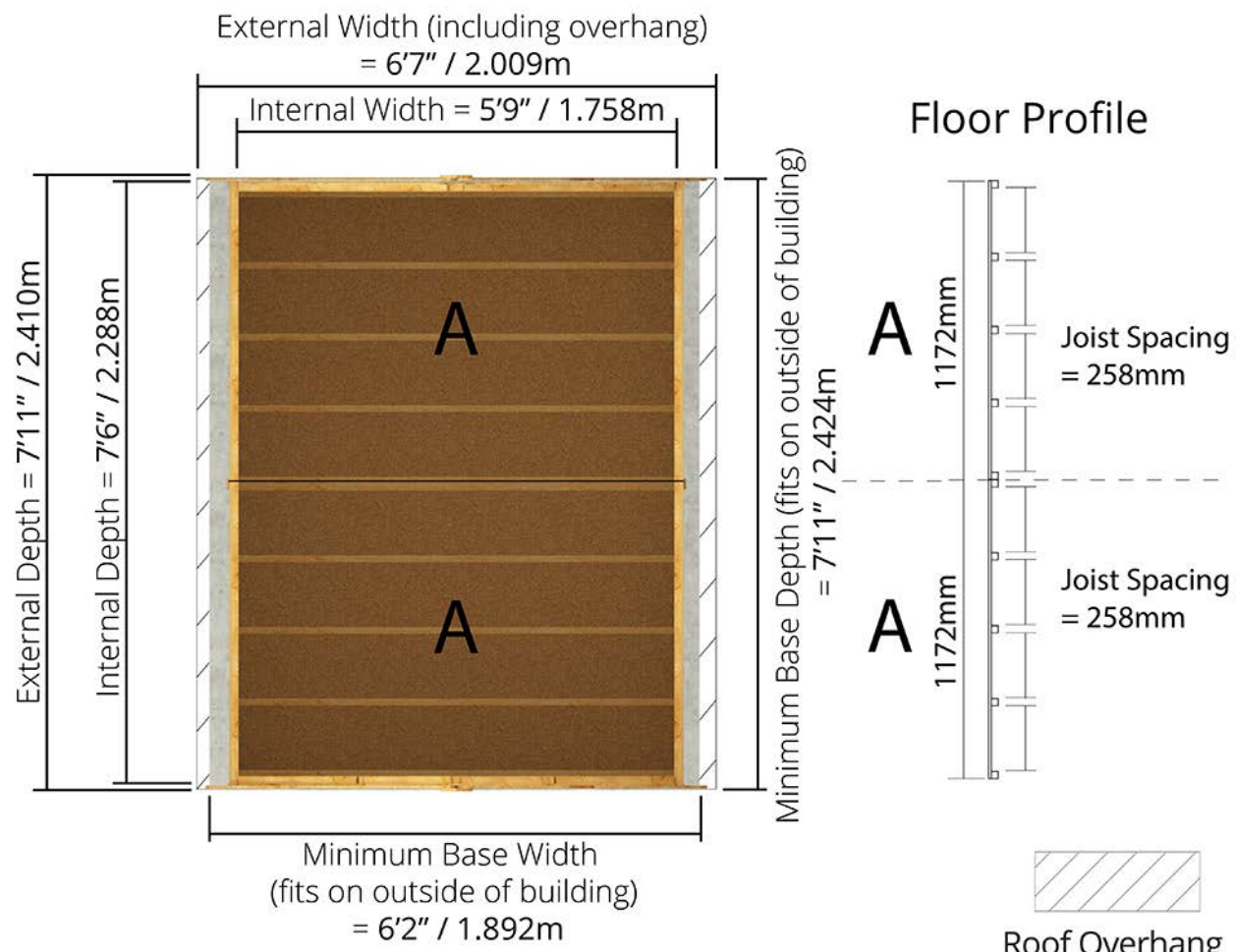

Front of Building

Please note: your base must be perfectly level and drainage is required to allow water to run off the surface. There must also be at least 2m clearance on each side to allow annual treatment to be applied.

# D1.238m x W2.009m / D6' 7" x W4'1"

## Windowed Overlap Apex Shed:

### Side elevation

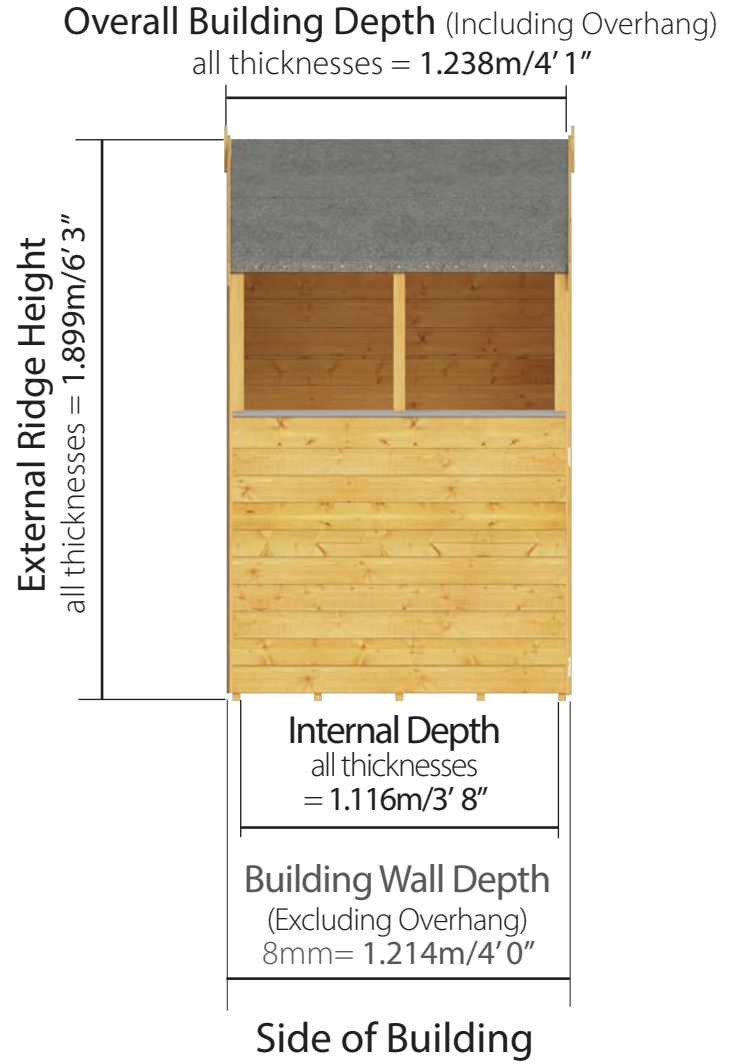

### Floor Plan

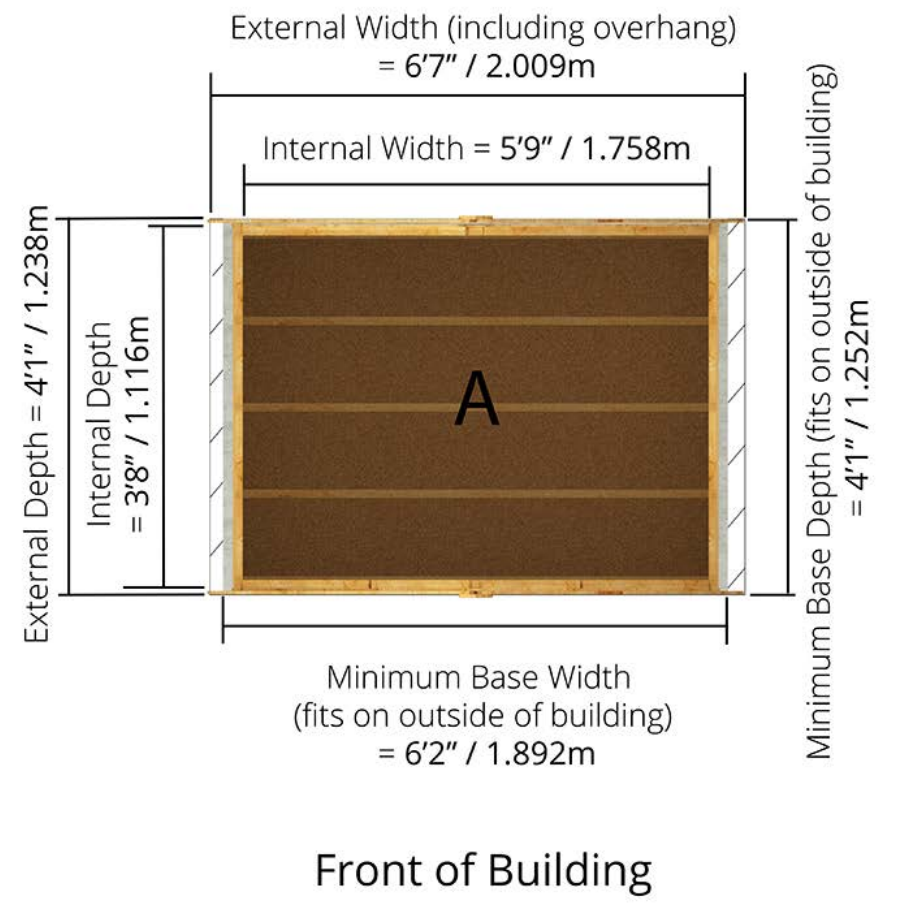

### Floor Profile

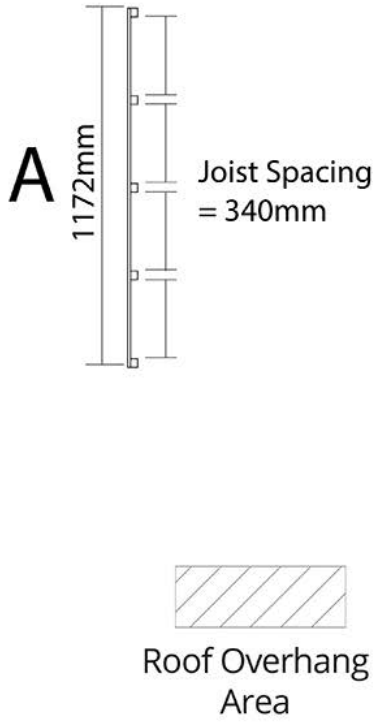

Please note: your base must be perfectly level and drainage is required to allow water to run off the surface. There must also be at least 2m clearance on each side to allow annual treatment to be applied.